

FOR OFFICIAL USE

| | | | | | |
|--|--|--|--|--|--|
| | | | | | |
|--|--|--|--|--|--|

X008/201

Total for
Sections B and C

| |
|--|
| |
|--|

NATIONAL
QUALIFICATIONS
2009

FRIDAY, 22 MAY
1.00 PM – 3.00 PM

BIOTECHNOLOGY
INTERMEDIATE 2

Fill in these boxes and read what is printed below.

Full name of centre

| |
|--|
| |
|--|

Town

| |
|--|
| |
|--|

Forename(s)

| |
|--|
| |
|--|

Surname

| |
|--|
| |
|--|

Date of birth

Day Month Year

| | | | | | | | |
|--|--|--|--|--|--|--|--|
| | | | | | | | |
|--|--|--|--|--|--|--|--|

Scottish candidate number

| | | | | | | | | | |
|--|--|--|--|--|--|--|--|--|--|
| | | | | | | | | | |
|--|--|--|--|--|--|--|--|--|--|

Number of seat

| |
|--|
| |
|--|

SECTION A (25 marks)

Instructions for completion of **Section A** are given on page two.

For this section of the examination you must use an **HB pencil**.

SECTION B AND SECTION C (75 marks)

- (a) All questions should be attempted.
(b) It should be noted that in **Section C** questions 1 and 2 each contain a choice.
- The questions may be answered in any order but all answers are to be written in the spaces provided in this answer book, **and must be written clearly and legibly in ink**.
- Additional space for answers will be found at the end of the book. If further space is required, supplementary sheets may be obtained from the invigilator and should be inserted inside the **front** cover of this book.
- The numbers of questions must be clearly inserted with any answers written in the additional space.
- Rough work, if any should be necessary, should be written in this book and then scored through when the final copy has been written. If further space is required, a supplementary sheet for rough work may be obtained from the invigilator.
- Before leaving the examination room you must give this book to the invigilator. If you do not, you may lose all the marks for this paper.



SECTION A

Read carefully

- 1 Check that the answer sheet provided is for **Biotechnology Intermediate 2 (Section A)**.
- 2 For this section of the examination you must use an **HB pencil** and, where necessary, an eraser.
- 3 Check that the answer sheet you have been given has **your name, date of birth, SCN** (Scottish Candidate Number) and **Centre Name** printed on it.
Do not change any of these details.
- 4 If any of this information is wrong, tell the Invigilator immediately.
- 5 If this information is correct, **print** your name and seat number in the boxes provided.
- 6 The answer to each question is **either** A, B, C or D. Decide what your answer is, then, using your pencil, put a horizontal line in the space provided (see sample question below).
- 7 There is **only one correct** answer to each question.
- 8 Any rough working should be done on the question paper or the rough working sheet, **not** on your answer sheet.
- 9 At the end of the exam, put the **answer sheet for Section A inside the front cover of this answer book**.

Sample Question

Which of the following foods contains a high proportion of fat?

- A Butter
- B Bread
- C Sugar
- D Apple

The correct answer is **A**—Butter. The answer **A** has been clearly marked in **pencil** with a horizontal line (see below).

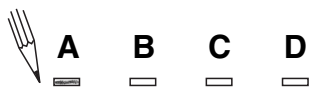

Changing an answer

If you decide to change your answer, carefully erase your first answer and using your pencil, fill in the answer you want. The answer below has been changed to **D**.

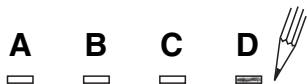

SECTION A

All questions in this Section should be attempted.

Answers should be given on the separate answer sheet provided.

1. Which line in the table below describes correctly the structure of algae?

| | Nucleus | Cell membrane | Cell wall |
|---|---------|---------------|-----------|
| A | Present | Present | Present |
| B | Absent | Present | Absent |
| C | Present | Absent | Absent |
| D | Present | Absent | Present |

2. The length of the protozoan, *Paramecium*, is 0.15 mm.

The length of the *Paramecium* in micrometres (1 millimetre = 1000 micrometres) is

- A 0.00015
- B 0.015
- C 1.5
- D 150.

3. The diagram below shows a protozoan.

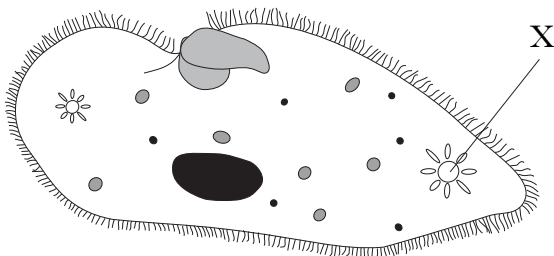

The function of structure X is to

- A control the activities of the cell
- B remove excess water
- C control the entrance and exit of materials
- D make food.

4. Viruses have a
- A DNA/RNA core and a non-cellular structure
 - B protein core and a non-cellular structure
 - C DNA/RNA core and a cellular structure
 - D protein core and a cellular structure.

5. The branched key below shows the shapes and arrangement of some bacteria.

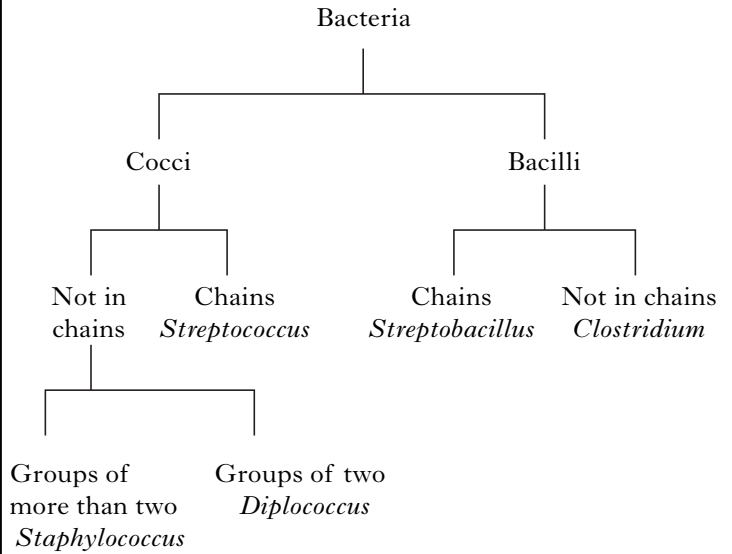

Use the key to identify the micro-organism shown below.

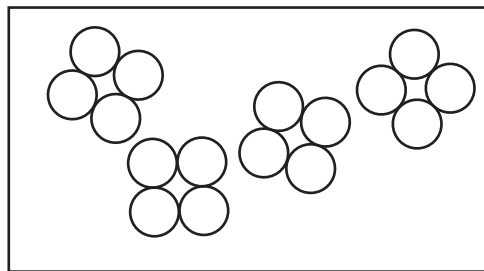

- A *Clostridium*
- B *Diplococcus*
- C *Staphylococcus*
- D *Streptococcus*

6. The enzyme amylase breaks down
- A cellulose
 - B glucose
 - C lactose
 - D starch.

[Turn over

Questions 7 and 8 are based on the information shown in the graph below.

The change in the number of *B. subtilis* growing in nutrient broth culture at 30°C for 20 hours is shown in the graph.

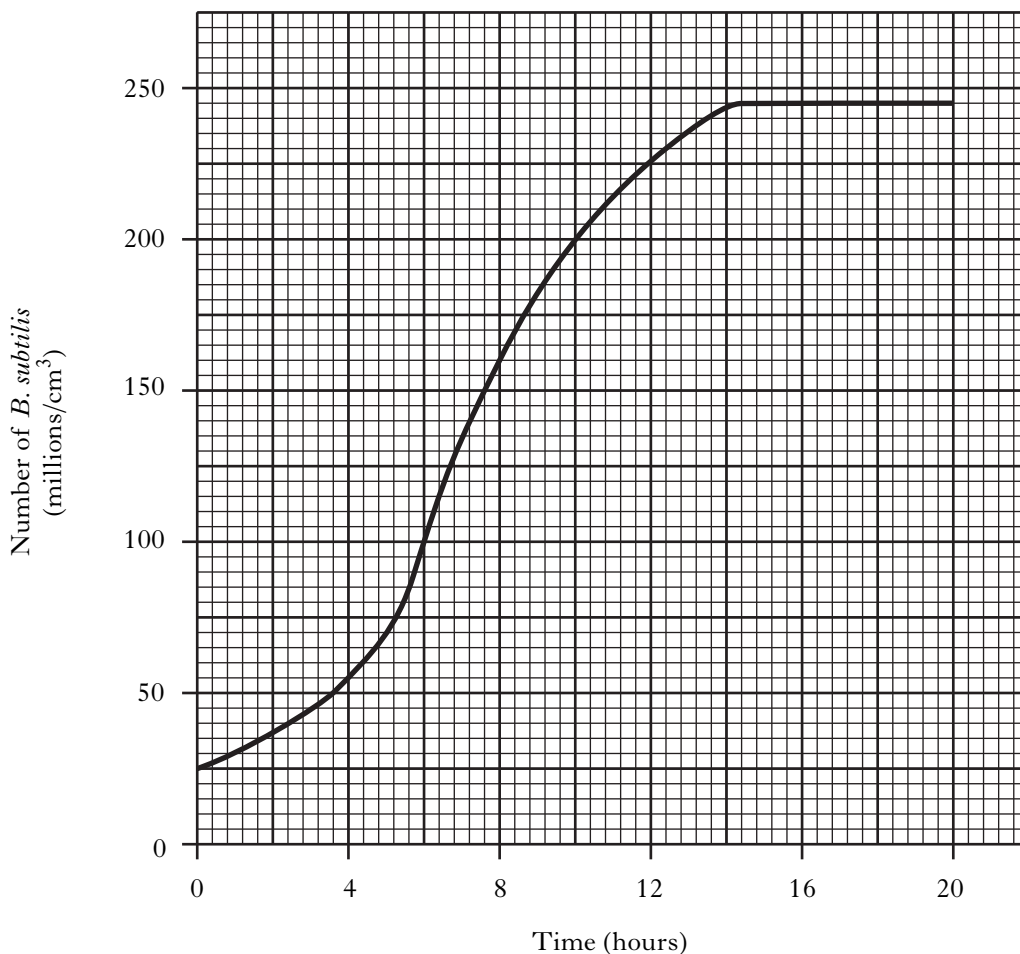

7. During which 4 hour period did the number of *B. subtilis* double in the nutrient broth culture?
- A 4–8 hours
 - B 6–10 hours
 - C 8–12 hours
 - D 12–16 hours
8. The percentage increase in the number of *B. subtilis* in the nutrient broth culture between 0 hours and 6 hours is
- A 33.3%
 - B 75%
 - C 300%
 - D 400%.

9. Parasitic micro-organisms obtain their food from
- A dead organisms
 - B decaying materials
 - C living organisms
 - D photosynthesis.

10. *Mucor* was grown on the surface of a malt broth. The initial mass of the *Mucor* was 0.5 g and the final mass was 7.5 g.

The simple whole number ratio of the initial mass to the final mass is

- A 15 : 1
 - B 5 : 75
 - C 1 : 15
 - D 75 : 5.
11. Which one of the following is the correct description of a broad spectrum antibiotic?
- A It kills some types of bacteria
 - B It kills all types of micro-organisms
 - C It kills some types of viruses
 - D It kills all types of fungi
12. Which of the following treatments of sewage involves trickling the effluent through stones?
- A Activated sludge treatment
 - B Biological filters
 - C Methane digesters
 - D Sedimentation

13. Which line in the table below describes correctly the state of sludge and the conditions involved in its breakdown in sewage treatment?

| | <i>State of sludge</i> | <i>Conditions of break down</i> |
|---|------------------------|---------------------------------|
| A | solid | anaerobic |
| B | liquid | aerobic |
| C | solid | aerobic |
| D | liquid | anaerobic |

Questions 14 and 15 refer to the information in the table below.

Growth of *Aspergillus* is affected by the temperature and the presence of phosphate and nitrate in the culture medium. The table below shows the growth conditions in five separate cultures of *Aspergillus*.

| <i>Flask</i> | <i>Temperature (°C)</i> | <i>Phosphate concentration (g l⁻¹)</i> | <i>Nitrate concentration (g l⁻¹)</i> |
|--------------|-------------------------|---|---|
| 1 | 5 | 1.0 | 2.0 |
| 2 | 5 | 4.0 | 4.0 |
| 3 | 20 | 2.0 | 4.0 |
| 4 | 20 | 2.0 | 2.0 |
| 5 | 20 | 4.0 | 4.0 |

14. Which two flasks should be compared to find the effect of phosphate on the growth of *Aspergillus*?
- A 1 and 4
 - B 2 and 4
 - C 3 and 5
 - D 4 and 5
15. Which two flasks should be compared to find the effect of temperature on the growth of *Aspergillus*?
- A 1 and 4
 - B 2 and 3
 - C 2 and 4
 - D 2 and 5
16. Fungi are **not** involved in the production of
- A citric acid
 - B ethanol
 - C single cell protein
 - D yoghurt.

[Turn over

17. Which line in the table below describes correctly the production of a meat substitute by micro-organisms?

| | <i>Micro-organism involved</i> | <i>Raw material used</i> | <i>Effect on pollution</i> |
|---|--------------------------------|--------------------------|----------------------------|
| A | bacteria | whey | reduced |
| B | fungi | whey | reduced |
| C | bacteria | molasses | increased |
| D | fungi | molasses | increased |

18. Selective breeding programmes have been accelerated by the use of

- A tissue culture
- B genetic modification
- C genome mapping
- D antibiotics.

19. Micro-organisms which take up a vital stain are

- A alive and fixed to the slide
- B alive and not fixed to the slide
- C dead and fixed to the slide
- D dead and not fixed to the slide.

20. Which of the following word equations describes correctly the synthesis of a complex carbohydrate?

- A glucose \longrightarrow lipid
- B amino acid \longrightarrow starch
- C glucose \longrightarrow cellulose
- D amino acid \longrightarrow protein

21. Maximising antibiotic production depends on controlling levels of

- A light, pH and temperature
- B pH, temperature and nutrients
- C temperature, light and oxygen
- D nutrients, oxygen and light.

22. Reproducing plants by tissue culture involves

- A making many plants from a small sample
- B introducing desirable features from the same species
- C transferring disease resistance to plants
- D introducing desirable features from a different species.

23. Which line in the table below describes correctly batch processing?

| | <i>Raw materials</i> | <i>Products</i> |
|---|----------------------|------------------------|
| A | Added at start only | Removed during process |
| B | Added at start only | Removed at end only |
| C | Added during process | Removed at end only |
| D | Added during process | Removed during process |

24. The diagram below shows an experiment set up to find out if a bacterium could use the sugar lactose in respiration.

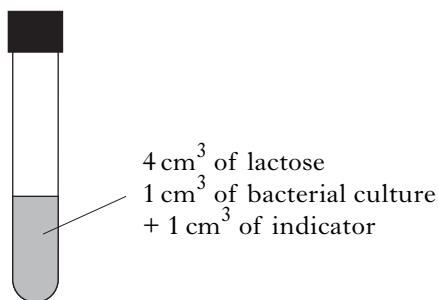

An indicator solution, which changes colour during respiration, was used to show if the bacterium had broken down the lactose.

Which line in the table below shows the correct contents of a control tube for this experiment?

| | <i>Volume of lactose (cm³)</i> | <i>Volume of bacterial culture (cm³)</i> | <i>Volume of indicator solution (cm³)</i> | <i>Volume of water (cm³)</i> |
|---|---|---|--|---|
| A | 4 | 0 | 1 | 0 |
| B | 0 | 0 | 1 | 5 |
| C | 4 | 1 | 0 | 0 |
| D | 0 | 1 | 1 | 4 |

25. The diagram below shows an investigation into the preservation of peas. All tubes were incubated at 20 °C for 24 hours.

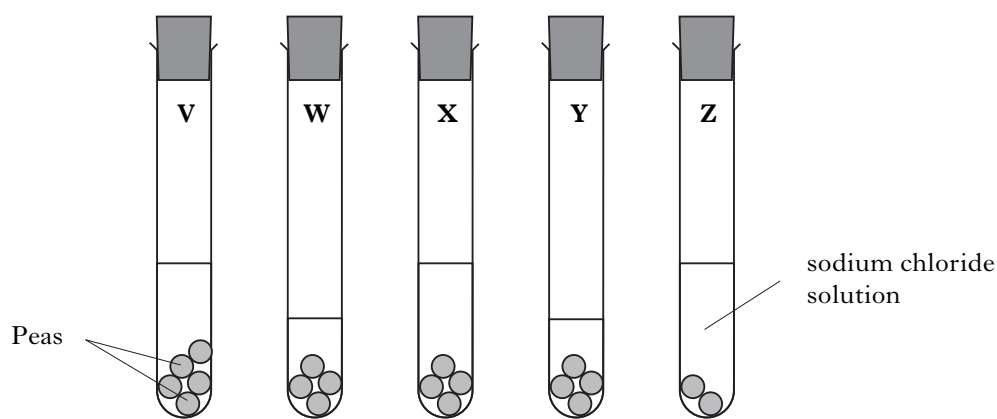

Concentration of sodium chloride (%) 0.1% 1.0% 0.1% 1.0% 0.1%

Which factor is under investigation when comparing tubes V, X and Z?

- A Concentration of sodium chloride
- B Temperature
- C Volume of sodium chloride
- D Number of peas

Candidates are reminded that the answer sheet for Section A MUST be returned INSIDE the front cover of this answer book.

SECTION B

**All questions in this section should be attempted.
All answers must be written clearly and legibly in ink.**

1. (a) The diagram below shows part of the nitrogen cycle.

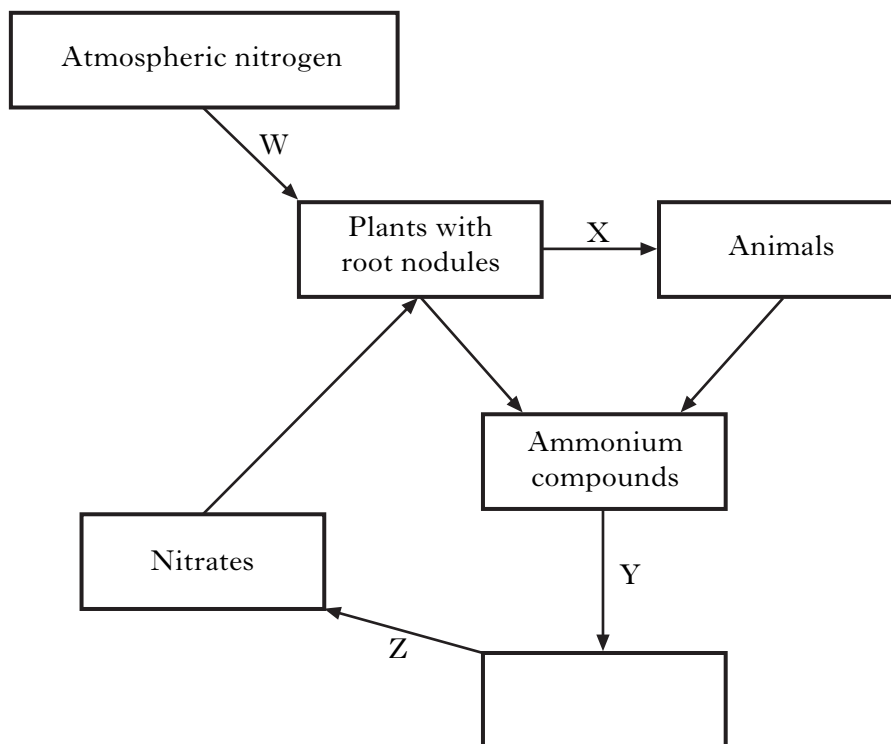

- (i) **Complete** the diagram by inserting the name of the correct chemical in the empty box. 1
- (ii) Which letter in the diagram identifies the process of nitrogen fixation?
Letter _____ 1
- (iii) Add an **arrow** to the diagram to show the process of denitrification. 1

Marks

1. (continued)

(b) The graph below shows the effect of adding an inoculant of nitrogen fixing bacteria on crop yields.

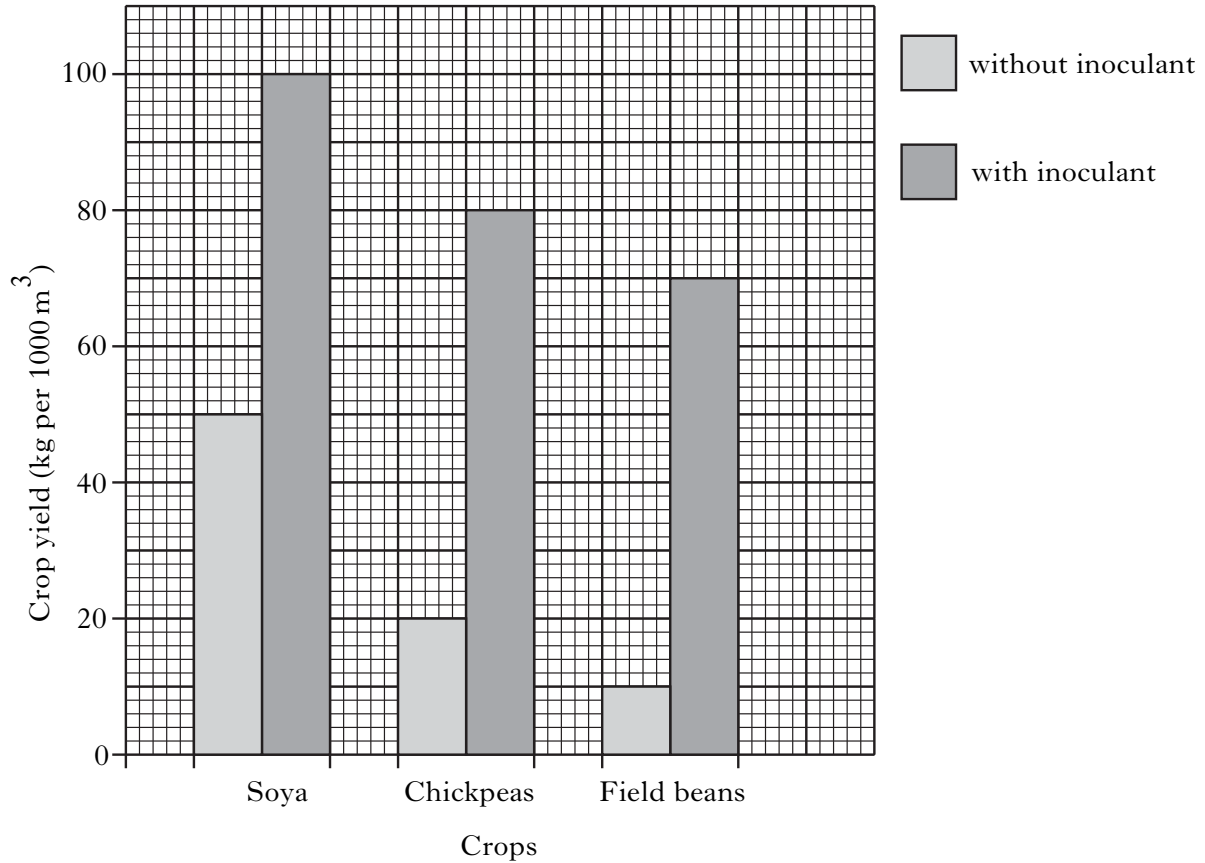

(i) How many times is the yield of chickpeas increased by using the inoculant?

Space for calculation

_____ times **1**

(ii) In which variety of crop was the inoculant **least** successful in increasing crop yield?

_____ **1**

What evidence from the graph supports your answer?

_____ **1**

(c) Identify the micro-organism involved in nitrogen fixation.

Underline the correct response.

Acetobacter Aspergillus Lactobacillus Rhizobium **1**

Marks

2. The diagram below shows the results of an investigation comparing the growth of *Mucor* on different types of agar.

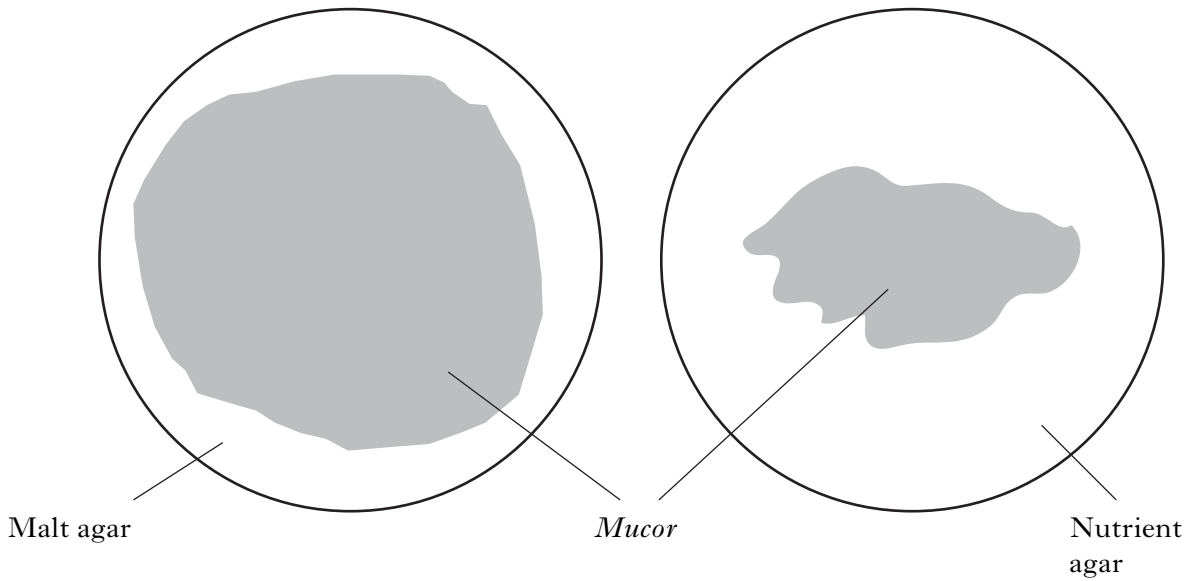

- (a) State **two** variables which should be kept the same to make this a valid experiment.

1 _____ 1

2 _____ 1

- (b) The diagram below shows the transfer of *Mucor* to the agar plates using a sterile cork borer.

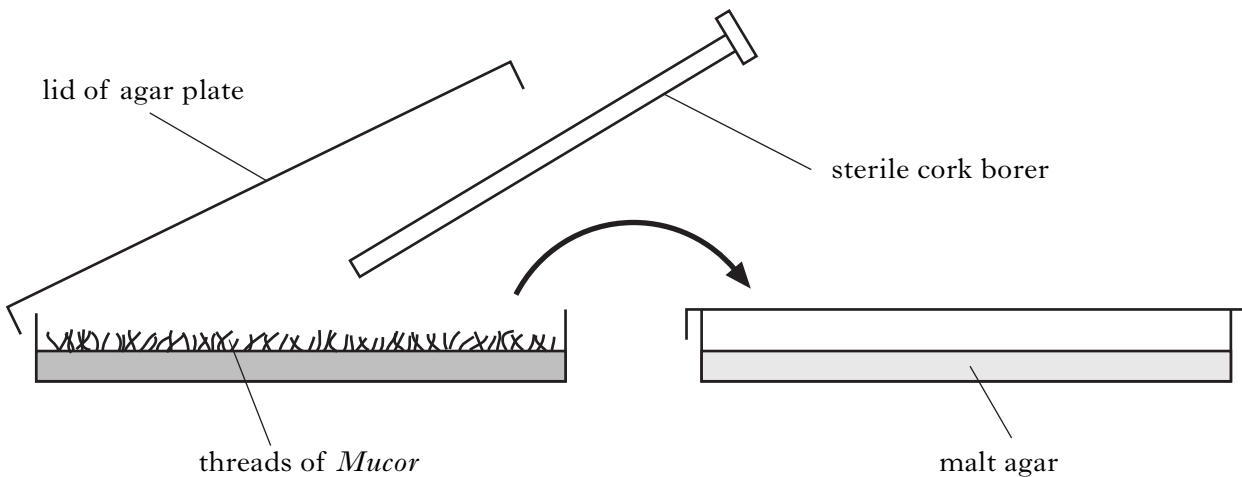

Give an advantage of using a cork borer, rather than a scalpel, for the transfer.

1

Marks

2. (continued)

The results were collected by measuring the area of *Mucor* growth on the plates.

(c) (i) Explain why it is difficult to measure the areas of growth of *Mucor*.

1

(ii) Suggest a suitable method for measuring these areas.

1

(d) Give one conclusion about the growth of *Mucor* in this experiment.

1

(e) Complete the following sentences about *Mucor* reproduction by underlining one of the options in each pair.

In *Mucor*, the fusion of gametes in $\left\{ \begin{array}{l} \text{asexual} \\ \text{sexual} \end{array} \right\}$ reproduction gives rise to $\left\{ \begin{array}{l} \text{sporangia} \\ \text{zygospores} \end{array} \right\}$.

2

[Turn over

Marks

3. The table below shows the results of an experiment to investigate the effect of light intensity on photosynthesis by *Chlorella*.

| <i>Light intensity</i> (units) | <i>Oxygen concentration</i> (%) |
|-----------------------------------|------------------------------------|
| 0 | 0 |
| 5 | 5 |
| 10 | 12 |
| 15 | 16 |
| 20 | 16 |

- (a) Plot a line graph of light intensity (units) against oxygen concentration (%).
(Additional graph paper, if required, can be found on page 29)

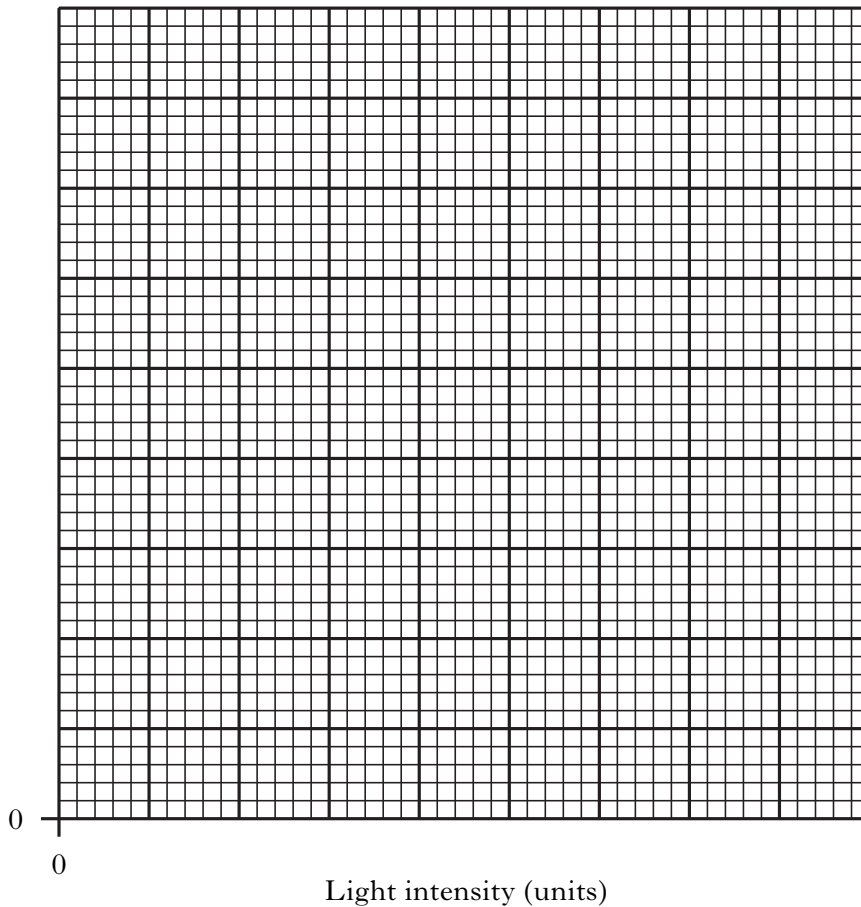

3

Marks

3. (continued)

(b) Predict the oxygen concentration at a light intensity of 25 units.

_____ units

1

(c) Name one factor which limits oxygen production between light intensities of

(i) 0 and 15 units _____

1

(ii) 15 and 20 units _____

1

(d) Decide if the following statements about photosynthesis by micro-organisms are **TRUE** or **FALSE** and tick (✓) the correct box.

If the statement is **FALSE**, write the correct word in the Correction box to replace the word in **bold** text in the statement.

| <i>Statement</i> | <i>True</i> | <i>False</i> | <i>Correction</i> |
|---|-------------|--------------|-------------------|
| Water and glucose are the raw materials needed for photosynthesis | | | |
| The type of micro-organism that makes a major contribution to global photosynthesis is algae | | | |

2

[Turn over

Marks

4. The table below shows some of the stages in the commercial production of human insulin by bacteria.

| | |
|---------|---|
| Stage 1 | Human insulin gene isolated |
| Stage 2 | Human insulin gene inserted into plasmid |
| Stage 3 | |
| Stage 4 | Bacteria grown and human insulin produced |
| Stage 5 | |

(a) Complete the table by describing what happens in Stages 3 and 5.

2

(b) Name the method for producing human insulin described above.

1

(c) Name the bacterium used in the production of human insulin.

1

(d) Give two benefits of producing human insulin using bacteria.

1 _____

1

2 _____

1

Marks

5. The diagram below shows the appearance of an agar plate inoculated with a mixed liquid culture of *E. coli* and *M. luteus*.



- (a) What name is given to the inoculation method used in setting up this agar plate?

_____ 1

- (b) Name a sterile instrument that could be used in this inoculation method to produce the result shown above.

_____ 1

- (c) Give two reasons for using this method of inoculation.

1 _____ 1

2 _____ 1

- (d) The plate above has **not** produced the expected results.

Suggest a possible source of error in the inoculation method.

_____ 1

[Turn over

Marks

6. The diagram below shows a light microscope used to view a slide of bacteria.

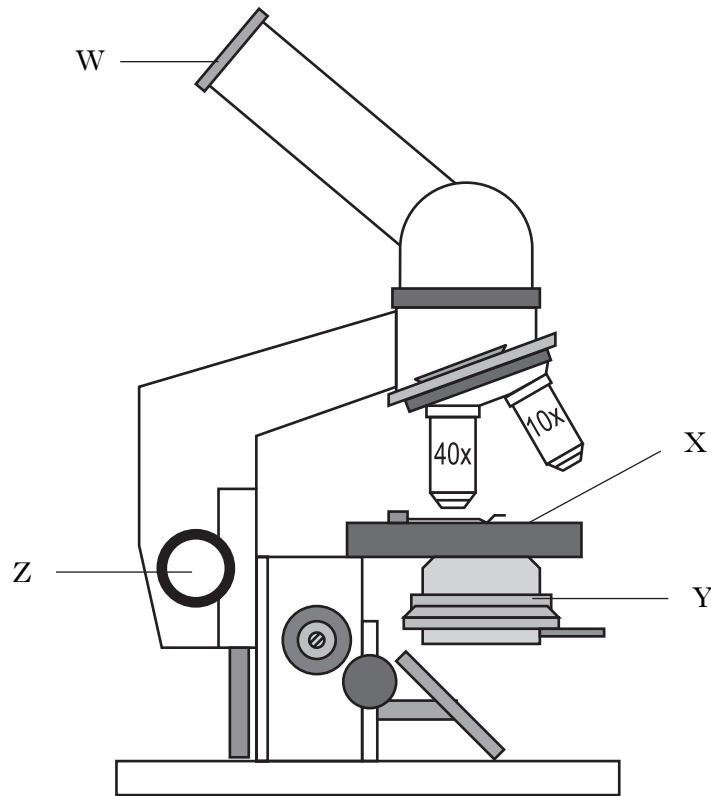

(a) Which letter identifies the focus control?

Letter _____

1

(b) State the function of the following parts of the microscope.

Stage _____

1

Objective lens _____

1

(c) The microscope has a 15x eyepiece lens and 10x, 20x and 40x objective lenses.

What is the highest total magnification available with these lenses?

Space for calculation

Highest total magnification _____

1

Marks

6. (continued)

- (d) The diagram below shows the shape of some bacteria under the microscope at a total magnification of 1000x.

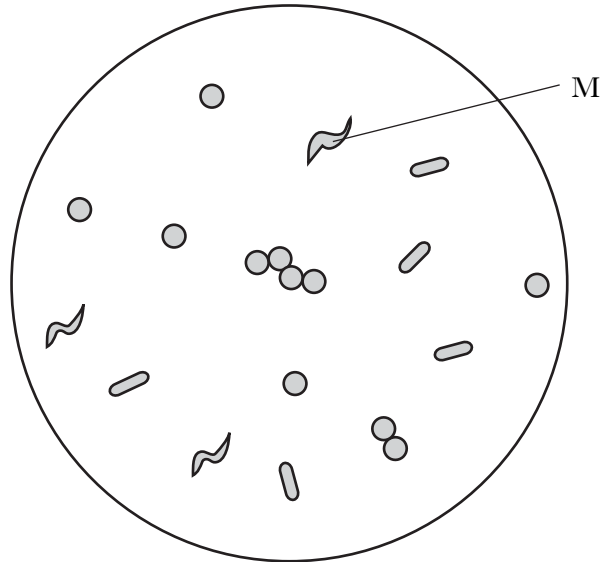

- (i) What term is used to describe the shape of bacteria M on this slide?

1

- (ii) Label a bacillus on the diagram above with the letter N.

1

- (iii) Compare the size of yeast cells to bacterial cells when viewed under the microscope at the same total magnification.

1

[Turn over

Marks

7. The diagram below shows some of the stages in the reproduction of yeast cells.

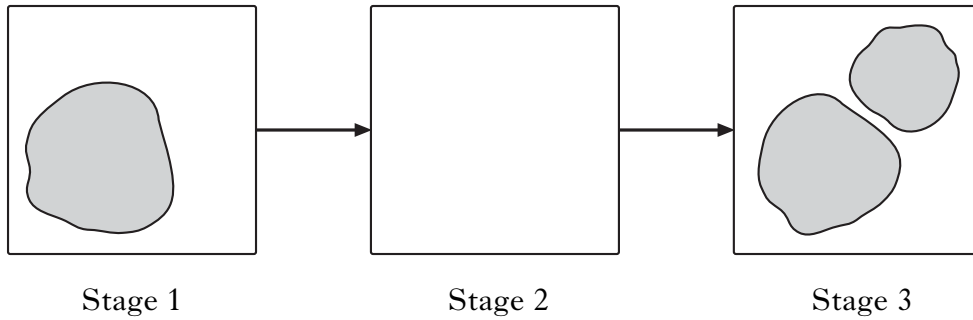

(a) (i) Complete the diagram by drawing a yeast cell to show what is happening at Stage 2. 1

(ii) Complete the following sentence by underlining one of the options in each pair.

The yeast cells shown in Stage 3 will be $\left\{ \begin{array}{l} \text{identical} \\ \text{non-identical} \end{array} \right\}$. These cells are produced $\left\{ \begin{array}{l} \text{sexually} \\ \text{asexually} \end{array} \right\}$ by $\left\{ \begin{array}{l} \text{conjugation} \\ \text{budding} \end{array} \right\}$. 2

(b) Yeast cells are capable of both aerobic and anaerobic respiration.

(i) Complete the word equation for aerobic respiration. 1

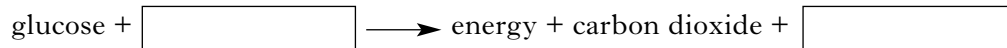

(ii) Yeast cells can obtain energy from both types of respiration.

Which type of respiration provides the higher energy yield?

_____ 1

(iii) Yeast cells are facultative anaerobes.

What advantage is there to a yeast cell in being a facultative anaerobe?

_____ 1

Marks

8. The dead leaves from beech trees fall onto the ground forming a layer. A mass of white fungal threads develops in this layer of leaves. These fungal threads are involved in the decay of the leaves.

(a) (i) What advantage do the fungi gain from this decay process?

1

(ii) What is the advantage of this decay process to the beech tree?

1

(b) These fungal threads are connected to the roots of the beech tree.

Name this association between the fungi and the tree.

1

(c) What name is given to the mass of white threads described above?

1

[Turn over

Marks

9. The flow chart below shows steps in the production of biofuel (ethanol) from plant biomass (wood).

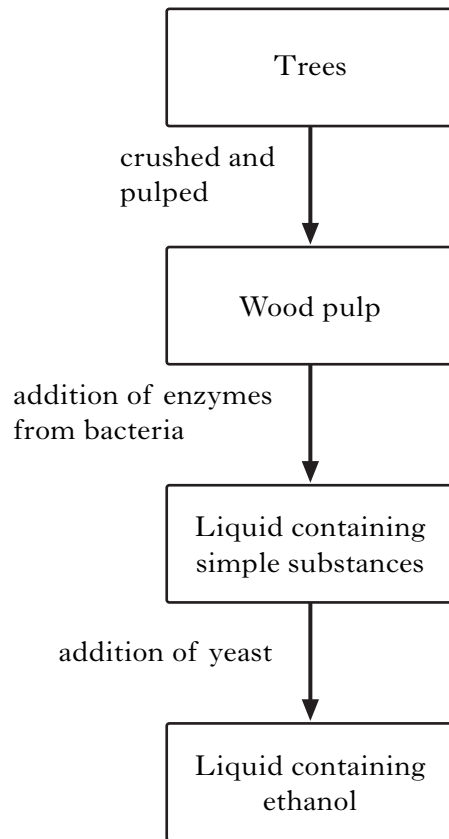

- (a) How many different types of organisms are involved in the production of this biofuel?

1

- (b) Name the process involved in the fixation of energy into plant biomass.

1

- (c) Name the simple substances that yeast converts into ethanol.

1

- (d) Name a process used to separate ethanol from the liquid mixture at the end of the production.

1

Marks

9. (continued)

(e) Yeast can convert simple substances into ethanol.

Name another micro-organism which can also convert simple substances into ethanol.

Underline the correct response.

Aspergillus

Acetobacter

Lactobacillus

Zygomonas

1

(f) State two benefits of biofuel.

1 _____

1

2 _____

1

[Turn over

Marks

10. The nutritional value of fresh grass can be preserved by a chemical produced by the action of micro-organisms. The preserved grass is called silage.

(a) (i) Name the type of micro-organism involved in silage production.

1

(ii) Name the chemical produced by the action of the micro-organisms which preserves the grass.

1

(iii) Explain how this chemical preserves the nutritional value of grass.

1

(b) The diagram below shows a trial to investigate whether adding an inoculum of micro-organisms improves silage quality.

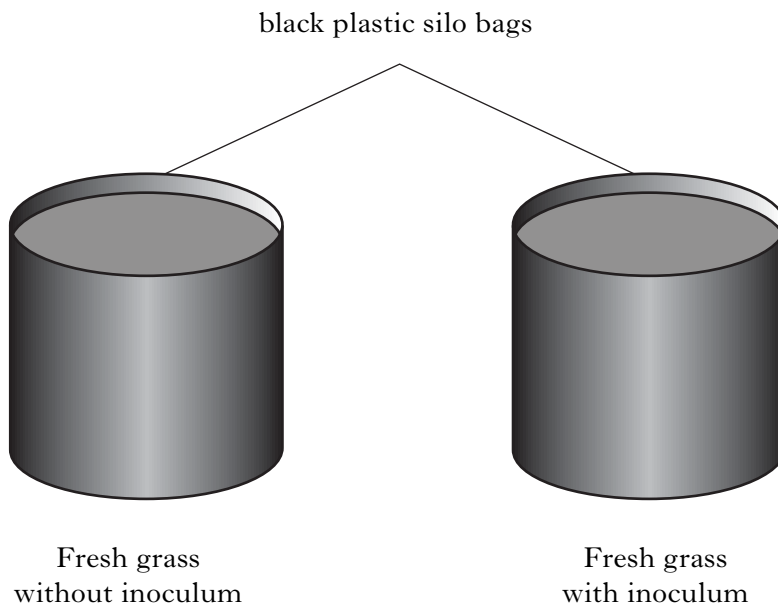

(i) State two variables which should be kept the same to make this trial valid.

1 _____

1

2 _____

1

Marks

10. (b) (continued)

- (ii) During silage production, the sugar concentration, the pH and the temperature change within the silo bags.

Complete the table by ticking (✓) **one** box in each line to predict what happens to these three factors during successful silage production.

| <i>Factor</i> | <i>Decrease</i> | <i>Stay the same</i> | <i>Increase</i> |
|-------------------------|-----------------|----------------------|-----------------|
| Sugar concentration (%) | | | |
| pH | | | |
| Temperature (°C) | | | |

2

[Turn over for Section C on Page twenty-four

SECTION C

Both questions in this section should be attempted.

Note that each question contains a choice.

Marks

Questions 1 and 2 should be attempted on the blank pages which follow.

Supplementary sheets, if required, may be obtained from the invigilator.

Labelled diagrams may be included where appropriate.

1. Answer either A or B.

A. The diagram below shows the structure of a bacterial cell and a fungal cell (not to scale).

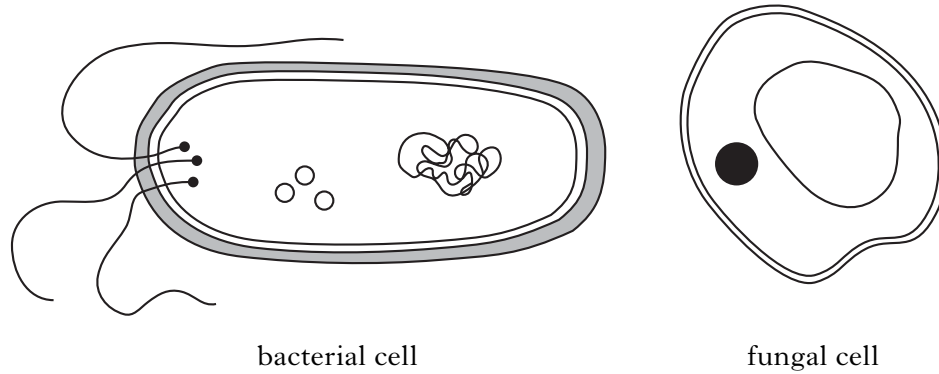

List the structures:

- (a) found in both cells;
- (b) found in only one of the cells.

(A table may be used in your answer if you wish)

5

OR

B. The diagram below shows a reaction involving extracellular enzymes.

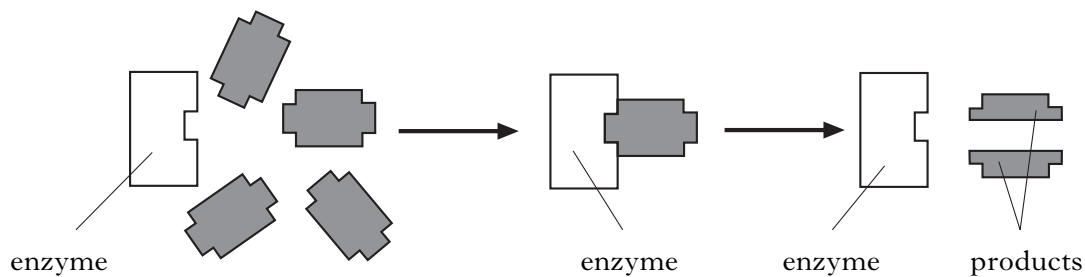

- (a) Describe what happens in an enzyme reaction.
- (b) Why are extracellular enzymes important to micro-organisms?

5

Question 2 is on page twenty-six

SPACE FOR ANSWER TO QUESTION 1

Please complete the box below to indicate which part, A or B, you are answering.

2. Answer **either A or B**.

A. Describe the steps taken to transfer a liquid sample of bacteria with an inoculating loop to a slide, ready for staining.

5

OR

B. Describe the steps taken to produce a good quality plate from a bottle of liquid agar provided at 95 °C.

5

[END OF QUESTION PAPER]

SPACE FOR ANSWER TO QUESTION 2

Please complete the box below to indicate which part, A or B, you are answering.

ADDITIONAL SPACE FOR ANSWERS

| |
|--|
| |
|--|

ADDITIONAL SPACE FOR ANSWERS

ADDITIONAL GRAPH PAPER FOR USE IN QUESTION 3(a)

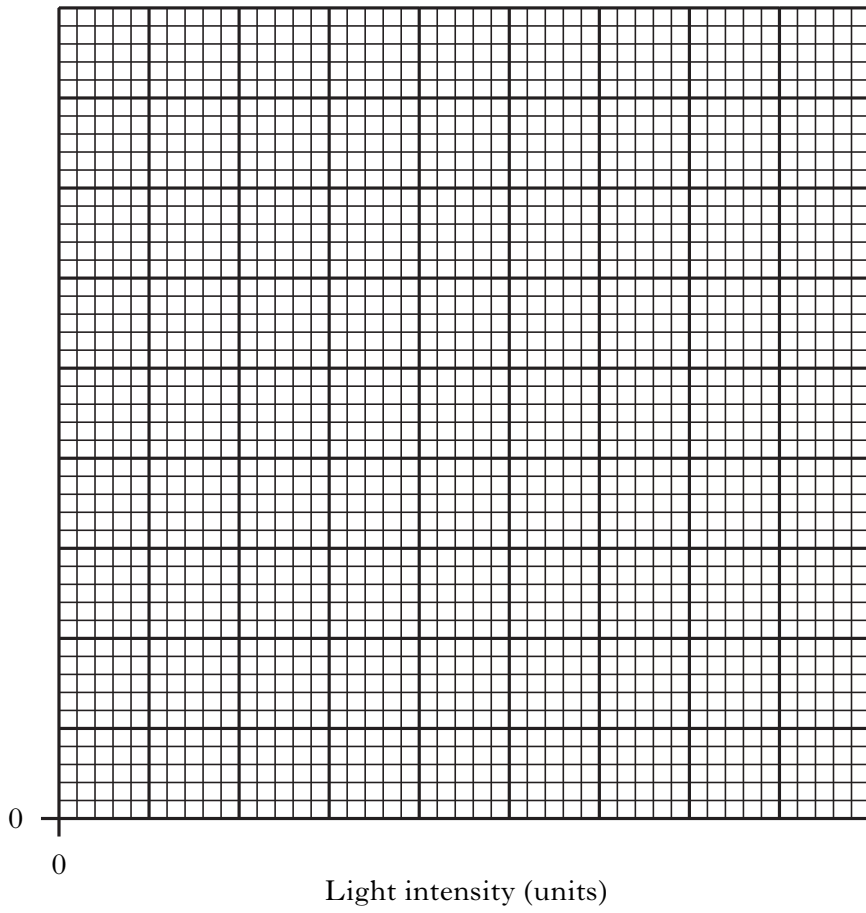

[BLANK PAGE]

[BLANK PAGE]

[BLANK PAGE]