

General information about practical exams

Centres must follow the guidance on science practical exams given in the *Cambridge Handbook*.

Safety

Supervisors must follow national and local regulations relating to safety and first aid.

Only those procedures described in the question paper should be attempted.

Supervisors must inform candidates that materials and apparatus used in the exam should be treated with caution. Suitable eye protection should be used where necessary.

Before the exam

- The packets containing the question papers must **not** be opened before the exam.
- It is assumed that standard school laboratory facilities, as indicated in the *Guide to Planning Practical Science*, will be available.
- Spare materials and apparatus for the tasks set must be available for candidates, if required.

During the exam

- It must be made clear to candidates at the start of the exam that they may request spare materials and apparatus for the tasks set.
- Where specified, the supervisor **must** perform the experiments and record the results as instructed. This must be done **out of sight** of the candidates, using the same materials and apparatus as the candidates.
- Any assistance provided to candidates must be recorded in the supervisor's report.
- If any materials or apparatus need to be replaced, for example, in the event of breakage or loss, this must be recorded in the supervisor's report.

After the exam

- The supervisor must complete a report for each practical session held and each laboratory used.
- Each packet of scripts returned to Cambridge International must contain the following items:
 - the scripts of the candidates specified on the bar code label provided
 - the supervisor's results relevant to these candidates
 - the supervisor's reports relevant to these candidates
 - seating plans for each practical session, referring to each candidate by candidate number
 - the attendance register.

Specific information for this practical exam

Number of sets of apparatus

In addition to a few spare sets, the minimum number of sets of apparatus to be provided should be sufficient to enable candidates to spend 20 minutes with the apparatus for each of Questions 1, 2 and 3, and one hour with the apparatus for Question 4. The order in which candidates answer the questions will be determined by the supervisor. Candidates may spend one hour circulating around Questions 1, 2 and 3, followed by an hour on Question 4, or vice versa.

It is assumed that candidates will supply their own calculator and geometrical instruments, such as a set square, 0° to 180° protractor, pair of compasses and 30 cm ruler. Candidates should be advised in advance that they may, if they wish, use wristwatches with stopwatch facilities, providing that such wristwatches afford the required precision.

Question 1

Items to be supplied by the Centre (per set of apparatus, unless otherwise specified):

- two expendable steel springs, with a spring constant of approximately 25 N/m e.g. Griffin catalogue number 12463080 or legacy number XBV-590-010H (see note 1)
- piece of card (see note 2)
- nut and bolt
- stand, boss and clamp
- three 10 g pieces of Blu Tack (see note 3)
- stopwatch reading to 0.1 s or better
- metre rule
- set square.

Notes

1. The springs should be joined together end to end by threading the loops at the end of each spring through each other as shown in Fig. 1.1.



Fig. 1.1

2. A piece of A4 card should be cut into four identical strips $29.7\text{ cm} \times 5.25\text{ cm}$ and stapled together. A small hole should be drilled in the card half way along its length and just above centre to allow a small bolt to pass through. The loop of one of the springs should be inserted into the centre of the strips and aligned with the hole in the card. The spring should be secured in this position by attaching a nut to the end of the bolt as shown in Fig. 1.2.

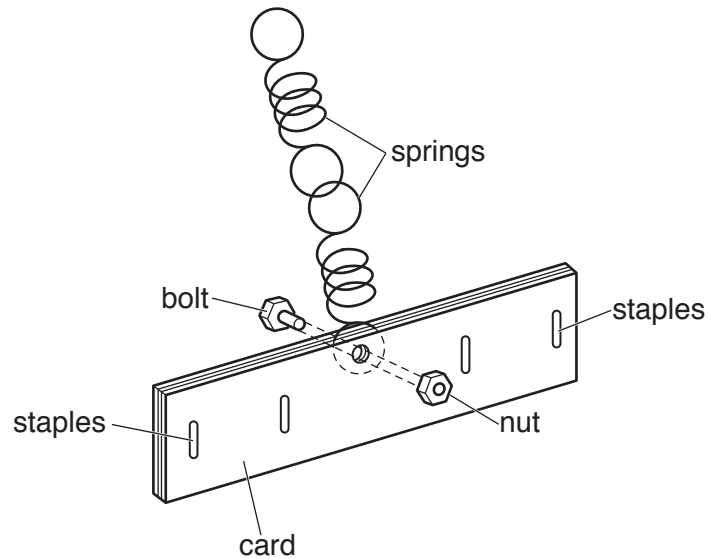

Fig. 1.2

The card should be marked with the labels A_1 , B_1 and C_1 , and A_2 , B_2 and C_2 in symmetrical positions using permanent marker as shown in Fig. 1.3.

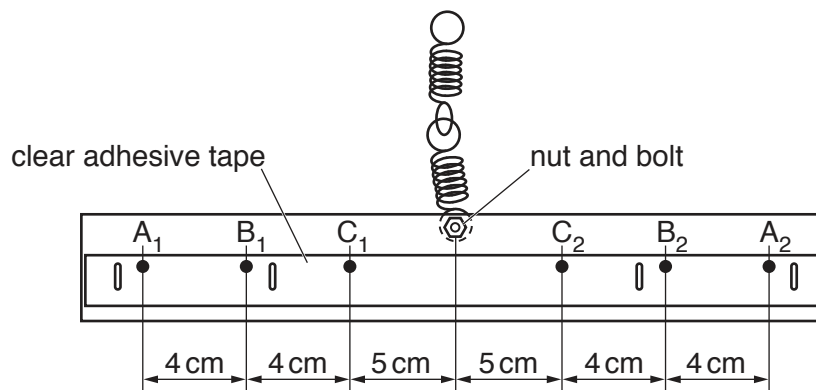

Fig. 1.3

The card should be covered with clear adhesive tape to allow Blu Tack to be attached and detached from the marked positions without damaging the surface.

3. Candidates will attach two pieces of Blu Tack to different marked positions on the card. Each piece should be 10 g in mass and rolled into a ball approximately 20 mm in diameter. A third piece of Blu Tack is also required.

At the changeover the supervisor should:

- remove the spring and card from the stand
- remove any Blu Tack from the marked card and the clamp and ensure that each piece is the correct size and shape described in note 3.

Information required by Examiners

Sample set of numerical results, clearly marked “supervisor’s results”, obtained out of sight of the candidates.

Question 2

Items to be supplied by the Centre (per set of apparatus, unless otherwise specified):

- two 1.0 m rules to make a track (see note 1)
- four pieces of Blu Tack (see note 1)
- two 5 mm spacers and one 10 mm spacer (see note 1)
- Blu Tack (see note 2)
- glass ball (see note 3)
- metre rule with mm divisions or 0.5 m ruler (see note 4)
- stopwatch reading to 0.1 s or better
- set square.

Notes

1. The track should be made from two 1.0 m rules with mm divisions. Three pieces of Blu Tack each of approximate mass 5 g and one piece of approximate mass 15 g should be placed along the length of one surface of one of the rules as shown in Fig. 2.1.

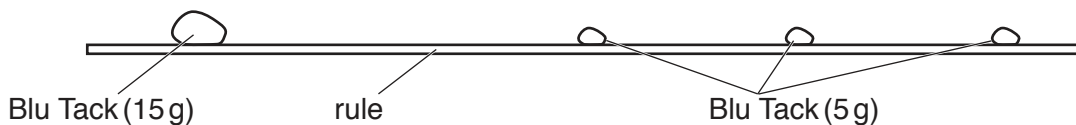

Fig. 2.1

Spacers of thickness 10 mm and 5 mm should be placed between the pieces of Blu Tack as shown in Fig. 2.2.

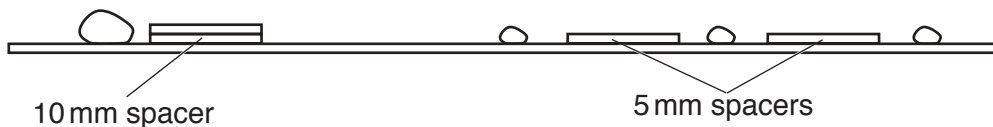

Fig. 2.2

A suitable spacer can be made using strips of A4 paper of length 6 cm and width 2 cm. A thickness of 5 mm is produced by layering approximately 48 strips and securing them together with an outer layer of adhesive tape to prevent them coming apart. Two 5 mm spacers should be used at the wide end to ensure that the track has a gap of 12 mm at its widest part tapering to 4 mm at the narrowest part. The second metre rule should be pressed firmly onto the Blu Tack to stick the rules together as shown in Fig. 2.3.

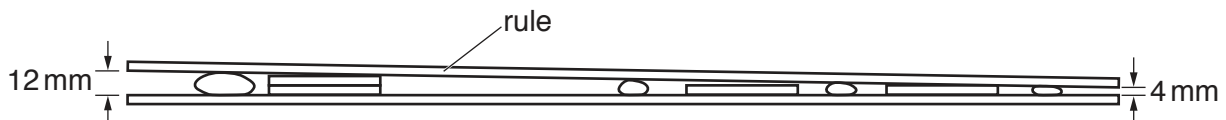

Fig. 2.3

Ensure that the Blu Tack and spacers are at least 3 mm below the top of the track so that the glass ball is able to roll unimpeded along the length of the track. The wide end of the track should be labelled A and the narrow end of the track should be labelled B.

2. A large piece of Blu Tack of approximate mass 80g should be moulded into a cylinder of approximate height 40mm and diameter 30mm. The wide end of the track should be pressed firmly into the Blu Tack so that the height of the bottom edge of the rule is 35mm as shown in Fig. 2.4.

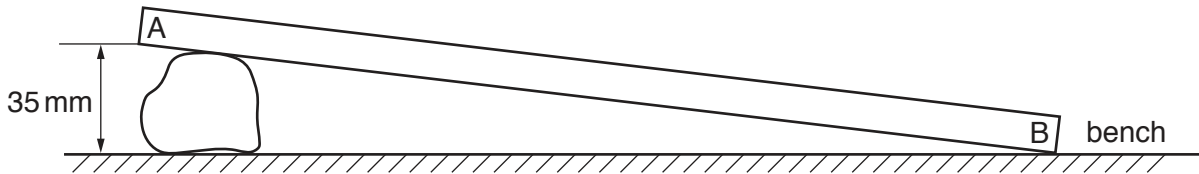

Fig. 2.4

The sides of the track should be perpendicular to the bench to ensure that the glass ball does not fall over the side of the track as it rolls down.

3. A glass ball of approximate diameter 15 mm should be used. A suitable glass ball is one that is commonly used in the children's game 'marbles'.
4. The rule should begin at zero with no dead space.

At the changeover the supervisor must restore the apparatus to the configuration shown in Fig. 2.4 with the wide end A of the track attached to the Blu Tack. The supervisor should check that the distance shown in Fig. 2.4 is 35 mm. It may also be necessary to have a replacement glass ball.

Information required by Examiners

Sample set of numerical results, clearly marked "supervisor's results", obtained out of sight of the candidates.

Question 3

Items to be supplied by the Centre (per set of apparatus, unless otherwise specified):

- lamp in a lamp holder (see note 1)
- connecting leads
- switch or plug key
- slit plate (see note 2)
- power supply (see note 3)
- protractor
- 30 cm ruler with mm scale
- Blu Tack (see note 1 and note 2).

Notes

1. One small torch lamp, of approximate diameter 1 cm, 2.5V, 250 mA, filament indicator lamp, clear e.g. RS 106-313, placed in a lamp holder e.g. RS 171-2503. The lamp holder must be fixed to the bench with a piece of Blu Tack and tilted as shown in Fig. 3.1.

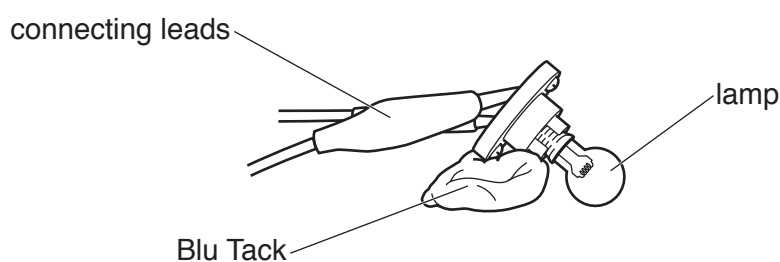

Fig. 3.1

A small gap must be left between the glass bulb of the lamp and the bench to allow a sheet of paper to slide underneath.

2. A slit plate may be found in a ray box kit if one is available but it must have the dimensions shown in Fig. 3.2. Alternatively, the plate should be cut from a piece of rigid card into a rectangle of length 80 mm and width 50 mm. Slits of width 1.0 mm and length 25 mm should be cut into the card at 12.5 mm, 25 mm and 37.5 mm as shown in Fig. 3.2.

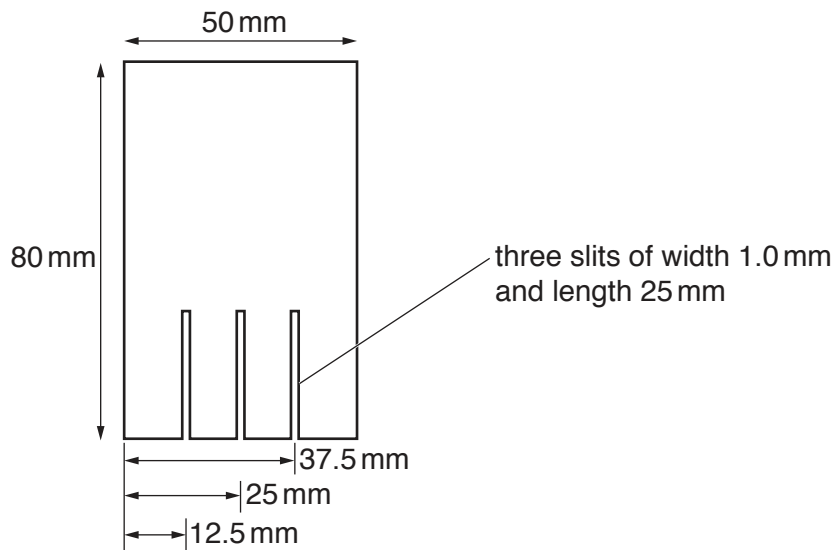

Fig. 3.2

Pieces of Blu Tack should be fixed to the bottom corners of the slit plate as shown in Fig. 3.3.

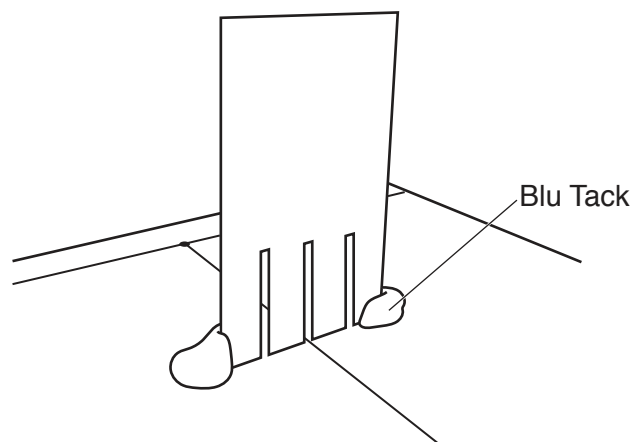

Fig. 3.3

Sufficient Blu Tack should be used to enable the slit plate to stand vertically without assistance from the candidate. Candidates will move the slit plate so the Blu Tack should **not** be pressed too firmly to the bench.

3. A power supply with potential difference of 3.0V is sufficient to power the lamp at a suitable brightness. The experiment must be performed in a darkened part of the laboratory.

The following are suitable power sources but all the candidates at a centre must be supplied with the same type of source:

- two 1.5V dry cells in suitable holders connected in series
- three 1.2V rechargeable cells in suitable holders connected in series
- d.c. power supply of 3V.

At the changeover the supervisor must ensure that the lamp is still working and replace it if necessary.

Information required by Examiners

Sample set of numerical results, clearly marked “supervisor’s results”, obtained out of sight of the candidates.

Question 4

Items to be supplied by the Centre (per set of apparatus, unless otherwise specified):

- 3.0V d.c. power supply (see note 1)
- switch or plug key
- resistor with a resistance of $10\text{ k}\Omega$ (see note 2)
- lamp and lamp holder (see note 3)
- light-dependent resistor (see note 4)
- paper (see note 5)
- stand, boss and clamp
- connecting leads (see note 6)
- voltmeter (see note 6)
- Blu Tack (see note 3 and note 4)
- rod, of approximate length 8 cm (see note 4)
- ruler with mm scale.

Notes

1. The following are suitable power sources but all the candidates at a centre must be supplied with the same type of source:
 - two 1.5V dry cells in suitable holders connected in series
 - three 1.2V rechargeable cells in suitable holders connected in series
 - d.c. power supply of 3V.
2. The $10\text{ k}\Omega$ fixed resistor is part of a circuit shown in Fig. 4.1 which must be set up by the supervisor. It must be possible to connect the leads from a voltmeter at points A, B and C. These points must be clearly labelled on the apparatus.

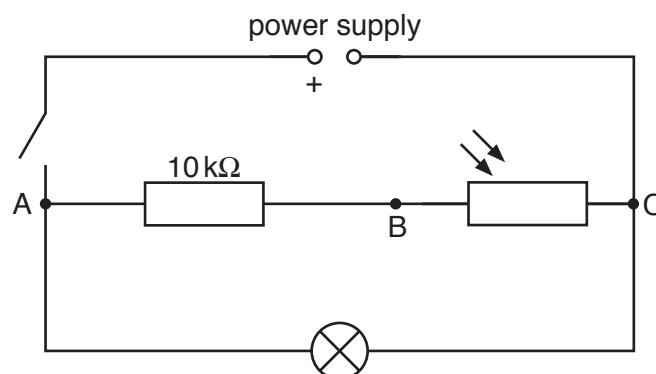

Fig. 4.1

The resistance of the LDR is affected by the background light level so the experiment must be performed in a darkened part of the laboratory.

3. Small torch lamp of approximate diameter 1 cm, 2.5V, 250 mA, filament indicator lamp, clear e.g. RS 106-313. It must be placed in a small holder e.g. RS 171-2503. The lamp holder should be attached to the base of the stand using a piece of Blu Tack to prevent it moving.
4. A suitable LDR is the Silonex NORPS-12. The RS component code is 914-6714. The LDR should be attached, using a piece of Blu Tack, to a rod of approximate length 8.0 cm as shown in Fig. 4.2.

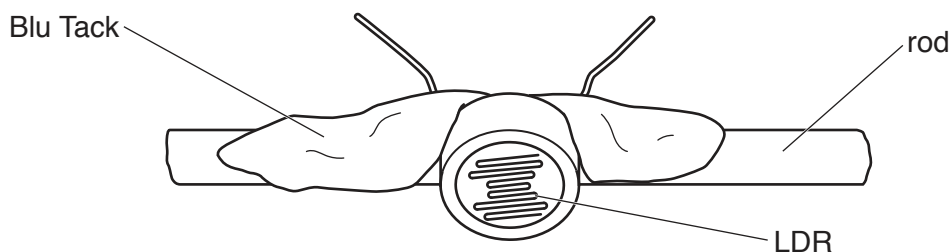

Fig. 4.2

The rod should be held in the jaws of the clamp with the LDR pointing downwards. The clamp should be attached to the stand and its position should be adjusted so that the LDR is directly above the lamp as shown in Fig. 4.3.

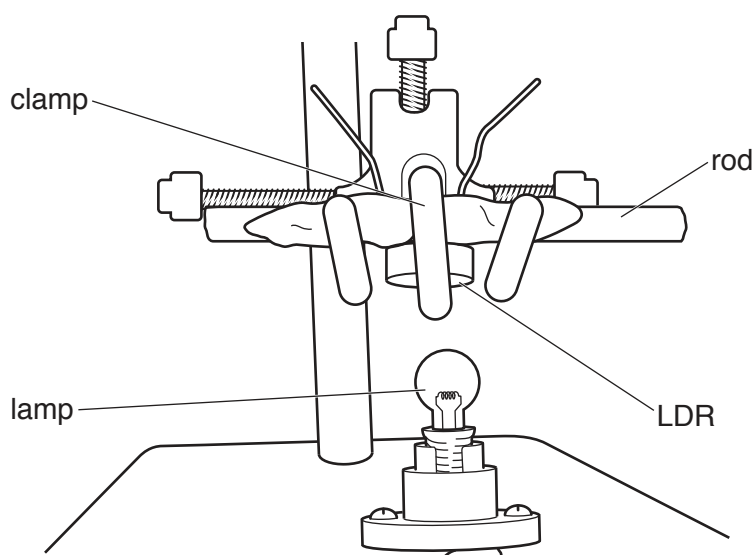

Fig. 4.3

There should be a 5 mm gap between the LDR and the lamp.

5. Six sheets of white 80 gsm paper (e.g. photocopier paper) approximately 6 cm × 6 cm.
6. Voltmeter capable of measuring a potential difference of up to 5.0V to a precision of 0.1V or better. An analogue or digital meter is suitable. The voltmeter must have two connecting leads (and crocodile clips if necessary). It must be possible to connect the leads from the voltmeter at points A, B, and C.

At the changeover the supervisor must ensure that the circuit is restored to the arrangement shown in Fig. 4.1 with the voltmeter disconnected and placed on one side. If cells have been used, check that they are still capable of producing 3.0V and replace them if necessary. Spare lamps should also be available.

Permission to reproduce items where third-party owned material protected by copyright is included has been sought and cleared where possible. Every reasonable effort has been made by the publisher (UCLES) to trace copyright holders, but if any items requiring clearance have unwittingly been included, the publisher will be pleased to make amends at the earliest possible opportunity.

To avoid the issue of disclosure of answer-related information to candidates, all copyright acknowledgements are reproduced online in the Cambridge Assessment International Education Copyright Acknowledgements Booklet. This is produced for each series of examinations and is freely available to download at www.cambridgeinternational.org after the live examination series.

Cambridge Assessment International Education is part of the Cambridge Assessment Group. Cambridge Assessment is the brand name of the University of Cambridge Local Examinations Syndicate (UCLES), which itself is a department of the University of Cambridge.

Supervisor's report

Syllabus and component number

				/		
--	--	--	--	---	--	--

Centre number

--	--	--	--	--

Centre name

Time of the practical session

Laboratory name/number

Give details of any difficulties experienced by the centre or by candidates (include the relevant candidate names and candidate numbers).

You must include:

- any difficulties experienced by the centre in the preparation of materials
- any difficulties experienced by candidates, e.g. due to faulty materials or apparatus
- any specific assistance given to candidates.

Declaration

- 1 Each packet that I am returning to Cambridge International contains the following items:
 - the scripts of the candidates specified on the bar code label provided
 - the supervisor's results relevant to these candidates
 - the supervisor's reports relevant to these candidates
 - seating plans for each practical session, referring to each candidate by candidate number
 - the attendance register
- 2 Where the practical exam has taken place in more than one practical session, I have clearly labelled the supervisor's results, supervisor's reports and seating plans with the time and laboratory name/number for each practical session.
- 3 I have included details of difficulties relating to each practical session experienced by the centre or by candidates.
- 4 I have reported any other adverse circumstances affecting candidates, e.g. illness, bereavement or temporary injury, directly to Cambridge International on a *special consideration form*.

Signed (supervisor)

Name (in block capitals)