



**Cambridge International Examinations**  
Cambridge International General Certificate of Secondary Education

**PHYSICS**

**0625/11**

Paper 1 Multiple Choice

**October/November 2015**

**45 minutes**

Additional Materials: Multiple Choice Answer Sheet  
Soft clean eraser  
Soft pencil (type B or HB recommended)

\* 3 1 6 8 3 1 5 3 3 5 \*

**READ THESE INSTRUCTIONS FIRST**

Write in soft pencil.

Do not use staples, paper clips, glue or correction fluid.

Write your name, Centre number and candidate number on the Answer Sheet in the spaces provided unless this has been done for you.

**DO NOT WRITE IN ANY BARCODES.**

There are **forty** questions on this paper. Answer **all** questions. For each question there are four possible answers **A, B, C** and **D**.

Choose the **one** you consider correct and record your choice in **soft pencil** on the separate Answer Sheet.

**Read the instructions on the Answer Sheet very carefully.**

Each correct answer will score one mark. A mark will not be deducted for a wrong answer.

Any rough working should be done in this booklet.

Electronic calculators may be used.

The syllabus is approved for use in England, Wales and Northern Ireland as a Cambridge International Level 1/Level 2 Certificate.

This document consists of **16** printed pages.

1 Which option contains **only** apparatus that could be used to determine the volume of a small block of unknown material?

- A measuring cylinder, metre rule
- B measuring cylinder, stopwatch
- C metre rule, balance
- D metre rule, stopwatch

2 The graph represents the motion of a car.

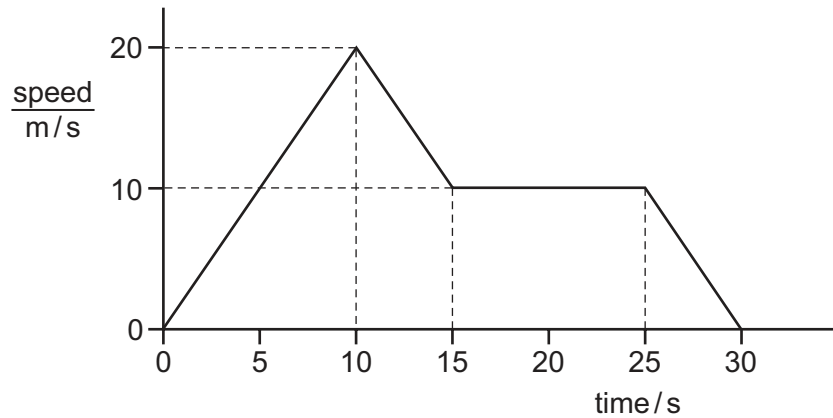

What is the distance travelled by the car while it is moving at a constant speed?

- A 100 m
- B 150 m
- C 250 m
- D 300 m

3 A car travels along the route PQRST in 30 minutes.

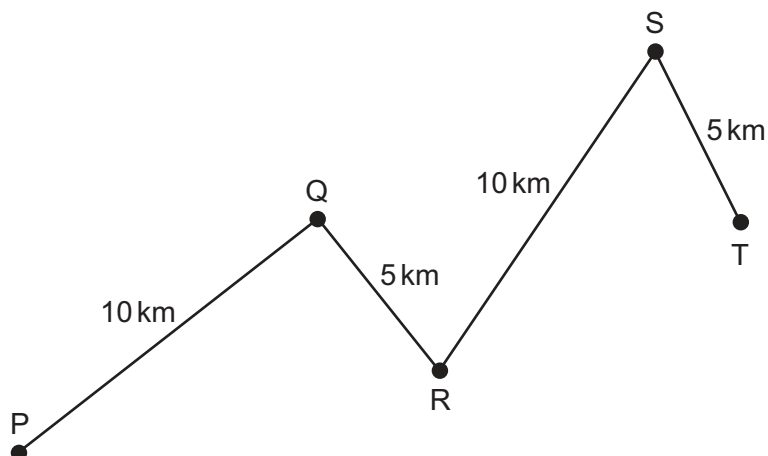

What is the average speed of the car?

- A 10 km/hour
- B 20 km/hour
- C 30 km/hour
- D 60 km/hour

- 4 The mass of an object is measured on Earth. The mass is 5.0 kg.

The object is taken to the Moon. The mass of the object is measured on the Moon.

What is the mass of the object on the Moon?

- A 0 kg
  - B more than 0 kg, but less than 5.0 kg
  - C 5.0 kg
  - D more than 5.0 kg
- 5 A student wishes to determine the density of the solid block shown.

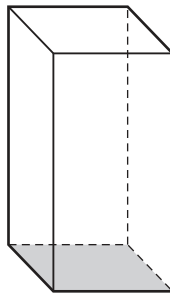

Which quantities must be known?

- A the area of the shaded face and the volume of the block
- B the area of the shaded face and the weight of the block
- C the mass of the block and the height of the block
- D the mass of the block and the volume of the block

- 6 A heavy beam rests on two supports. The diagram shows the only three forces  $F_1$ ,  $F_2$  and  $F_3$  acting on the beam.

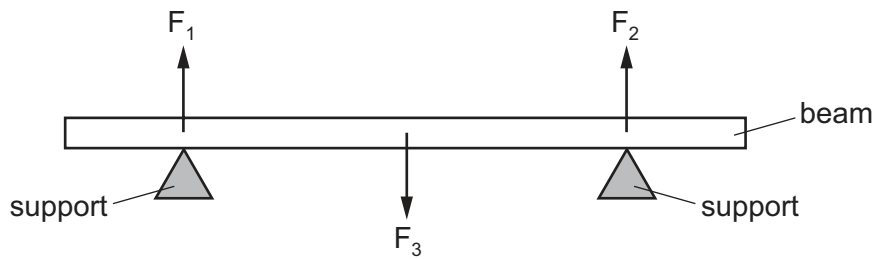

The beam is in equilibrium.

Which statement is correct?

- A** All the forces are equal in size.
- B** The resultant force on the beam is in the opposite direction to the resultant turning effect.
- C** The resultant force on the beam is zero and the resultant turning effect on the beam is zero.
- D** The total upward force is twice the total downward force.
- 7 Which list contains only properties of an object that can be changed by a force?
- A** direction of motion, mass, shape
- B** direction of motion, mass, speed
- C** direction of motion, shape, speed
- D** mass, shape, speed
- 8 What needs to be known to calculate the work done by a force acting on an object?

	the size of the force	the distance the force moves the object	the time for which the force acts
<b>A</b>	✓	✓	✓
<b>B</b>	✓	✓	✗
<b>C</b>	✓	✗	✓
<b>D</b>	✓	✗	✗

key

✓ = needed

✗ = not needed

- 9 Electrical energy may be obtained from nuclear fission.

In which order is the energy transferred in this process?

- A** nuclear fuel → generator → reactor and boiler → turbines  
**B** nuclear fuel → generator → turbines → reactor and boiler  
**C** nuclear fuel → reactor and boiler → generator → turbines  
**D** nuclear fuel → reactor and boiler → turbines → generator
- 10 The diagram shows a manometer containing a liquid. The manometer is used to find the difference between the pressure of a gas and atmospheric pressure.

Which distance represents this pressure difference?

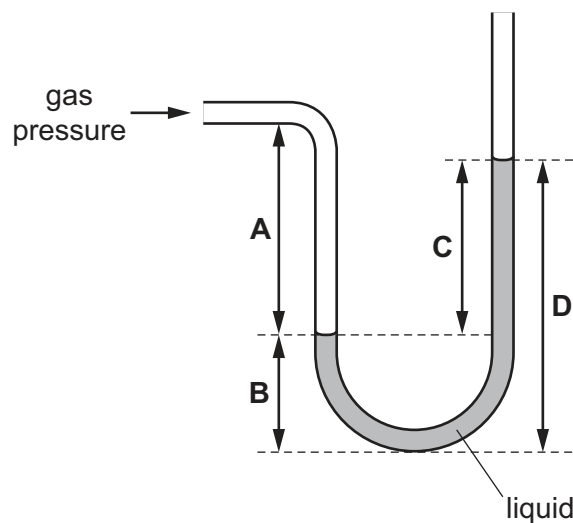

- 11 Four physics teachers investigate pressure. They wear identical clothes and lie on different beds of nails.

The table gives the weight of each teacher and the total area of contact between the teacher and the nails.

Which teacher experiences the least pressure from the nails?

	weight of teacher / N	total area of contact / cm <sup>2</sup>
<b>A</b>	700	13
<b>B</b>	800	20
<b>C</b>	900	14
<b>D</b>	1000	21

- 12 A cylinder of constant volume contains a fixed mass of gas. The gas is cooled.

What happens to the pressure of the gas and what happens to the kinetic energy of the gas molecules?

	pressure of gas	kinetic energy of molecules
<b>A</b>	decreases	decreases
<b>B</b>	decreases	increases
<b>C</b>	increases	decreases
<b>D</b>	increases	increases

- 13 A swimmer feels cold after leaving warm water on a warm, windy day.

Why does she feel cold even though the air is warm?

- A** The less energetic water molecules on her skin escape quickly.
- B** The more energetic water molecules on her skin do not escape quickly.
- C** The water on her skin does not evaporate quickly enough to keep her warm.
- D** The water on her skin evaporates quickly and cools her skin.

- 14 A circular metal disc is heated.

Which quantity decreases?

- A** its density
- B** its diameter
- C** its thickness
- D** its volume

- 15 The same quantity of thermal (heat) energy is given to two objects X and Y. The temperature rise of object X is less than the temperature rise of object Y.

What accounts for this difference?

- A** X has a larger thermal capacity than Y.
- B** X is a better thermal conductor than Y.
- C** Y has a larger thermal capacity than X.
- D** Y is a better thermal conductor than X.

- 16 The air in a room is heated by a heater. The diagram shows the circulation of the air in the room.

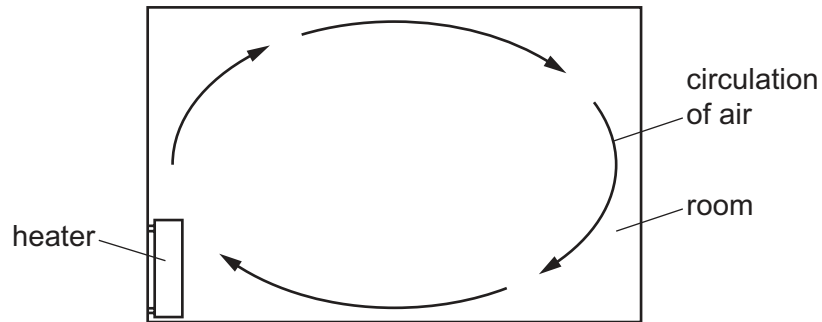

Which statement about the air that is heated is correct?

- A The air contracts and becomes less dense.
  - B The air contracts and becomes more dense.
  - C The air expands and becomes less dense.
  - D The air expands and becomes more dense.
- 17 Four rods are made from different metals P, Q, R and S. The rods have equal lengths and equal diameters. The rods are heated at one end, in the same way.

The table shows the time taken for the temperature at the other end of each rod to rise by  $1.0^{\circ}\text{C}$ .

Which metal is the best conductor of thermal energy (heat)?

metal	time taken/s
P	35
Q	30
R	45
S	40

- A metal P
- B metal Q
- C metal R
- D metal S

- 18 The diagram shows a side view of a water wave at a particular time. The diagram is drawn full size.

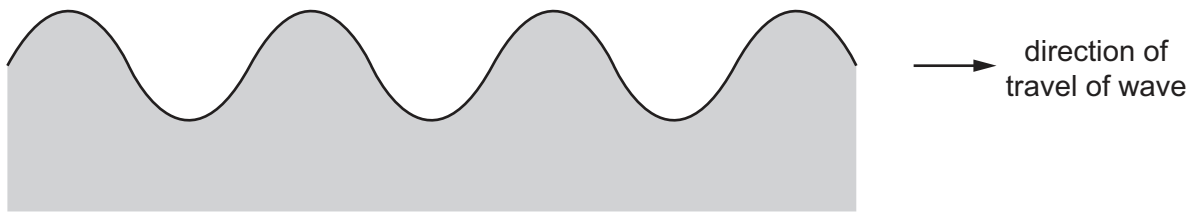

Which statement about the wave is correct?

- A The wave is longitudinal and the frequency can be measured from the diagram.
  - B The wave is longitudinal and the wavelength can be measured from the diagram.
  - C The wave is transverse and the frequency can be measured from the diagram.
  - D The wave is transverse and the wavelength can be measured from the diagram.
- 19 The diagram shows a water wave approaching a barrier with a gap.

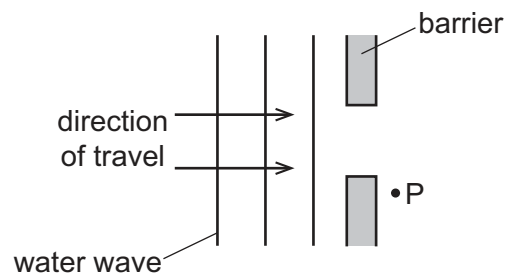

The wave reaches point P.

What is the name of the effect that causes the wave to reach point P?

- A diffraction
  - B dispersion
  - C reflection
  - D refraction
- 20 The diagram represents the electromagnetic spectrum.

Some regions have been labelled, and some labels are missing.

Which region should be labelled as infra-red waves?

radio waves	<b>A</b>	<b>B</b>	visible light	<b>C</b>	<b>D</b>	$\gamma$ -rays
-------------	----------	----------	---------------	----------	----------	----------------



- 21 A student draws a diagram representing three rays of light from point P passing through a converging lens. Each point labelled F is a principal focus of the lens.

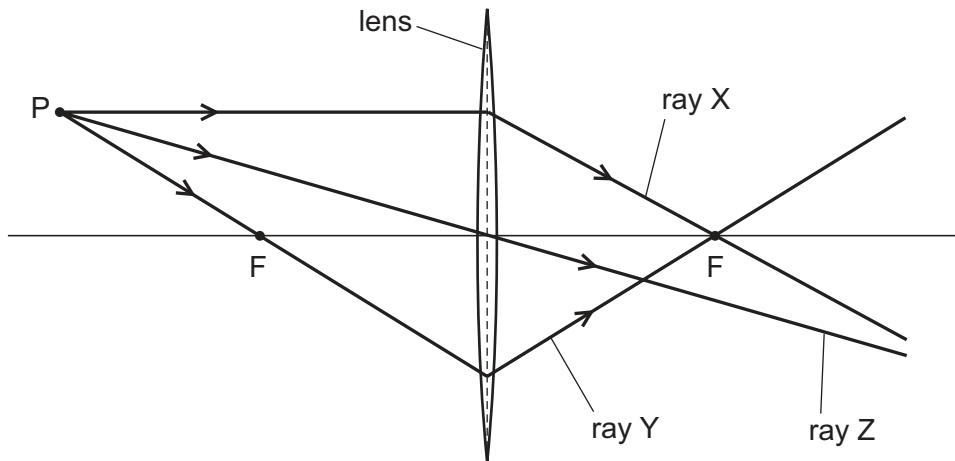

Which of the rays has the student drawn correctly?

- A** ray X and ray Y  
**B** ray X and ray Z  
**C** ray Y only  
**D** ray Z only
- 22 The diagram shows a ray of light inside a glass rod. The critical angle for the light in the glass is  $42^\circ$ .

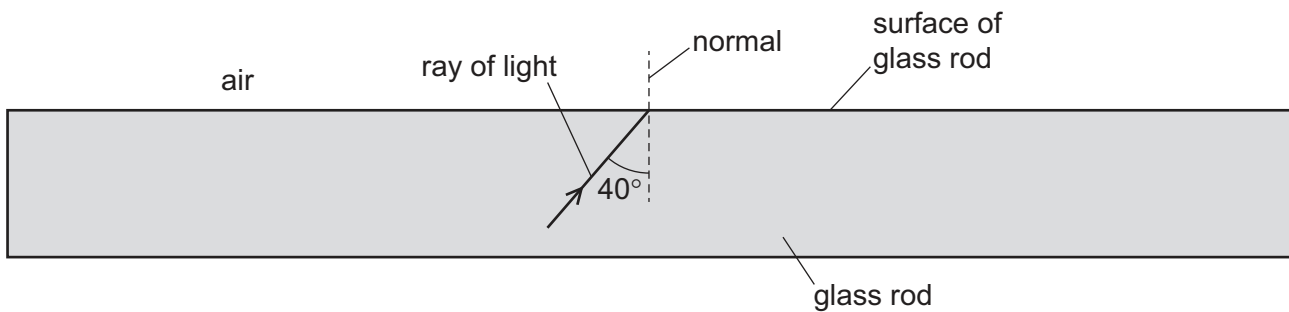

Which row shows what happens to the light when it reaches the surface of the glass rod?

	any light reflected?	any light refracted?
<b>A</b>	no	no
<b>B</b>	no	yes
<b>C</b>	yes	no
<b>D</b>	yes	yes

23 Which row states whether light waves and whether sound waves can travel in a vacuum?

	sound waves	light waves
<b>A</b>	no	no
<b>B</b>	no	yes
<b>C</b>	yes	no
<b>D</b>	yes	yes

24 Sounds are produced by vibrating objects. A certain object vibrates but a person nearby cannot hear any sound.

Which statement could explain why nothing is heard?

- A** The amplitude of the sound waves is too large.
- B** The frequency of the vibration is too high.
- C** The sound waves are transverse.
- D** The speed of the sound waves is too high.

25 Which row states whether each metal is ferrous or non-ferrous?

	ferrous	non-ferrous
<b>A</b>	aluminium	copper
<b>B</b>	copper	iron
<b>C</b>	iron	steel
<b>D</b>	steel	aluminium

26 Which procedure may be used to demagnetise a steel bar?

- A** cooling it in a freezer for several hours
- B** earthing it with a copper wire for several seconds
- C** removing it slowly from a coil carrying an alternating current (a.c.)
- D** rubbing it in one direction with a woollen cloth

27 What is the unit of electrical power?

- A** ampere
- B** joule
- C** volt
- D** watt

- 28 Some resistors are made using one type of wire. Two different lengths of wire are available. Each length is available in two different diameters.

Which wire has the highest resistance?

- A the wire with the greater length and the larger diameter
- B the wire with the greater length and the smaller diameter
- C the wire with the smaller length and the larger diameter
- D the wire with the smaller length and the smaller diameter

- 29 Four students are each given an identical resistor and asked to find its resistance. They each measure the potential difference across the resistor and the current in it.

One student makes a mistake.

Which row shows the results of the student that makes a mistake?

	potential difference /V	current /A
<b>A</b>	1.2	0.500
<b>B</b>	2.4	1.100
<b>C</b>	1.5	0.625
<b>D</b>	3.0	1.250

- 30 What is the circuit symbol for a variable resistor?

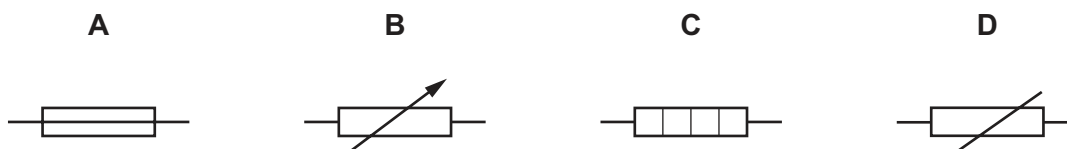

- 31 The diagram shows a circuit containing three ammeters P, Q and R.

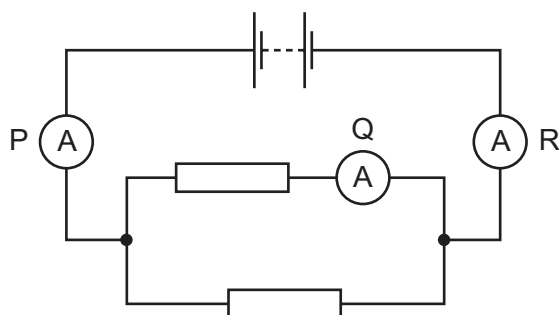

Which statement about the readings on the ammeters is correct?

- A The reading on P is equal to the reading on Q.
  - B The reading on P is equal to the reading on R.
  - C The reading on Q is greater than the reading on P.
  - D The reading on Q is greater than the reading on R.
- 32 The diagram shows a light-dependent resistor (LDR) connected in a potential divider circuit.

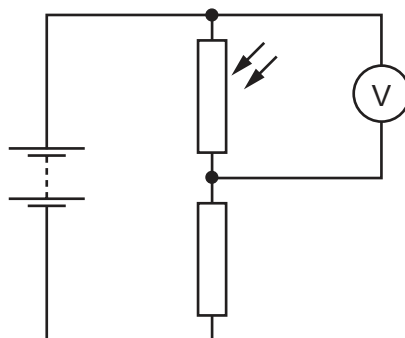

The brightness of the light falling on the LDR is increased.

Which row shows what happens to the resistance of the LDR, and what happens to the reading on the voltmeter?

	resistance of LDR	reading on voltmeter
<b>A</b>	decreases	decreases
<b>B</b>	decreases	increases
<b>C</b>	increases	decreases
<b>D</b>	increases	increases

33 Four lamps are each labelled '60 W 230 V'.

In which circuit are the lamps connected so that they operate at normal brightness?

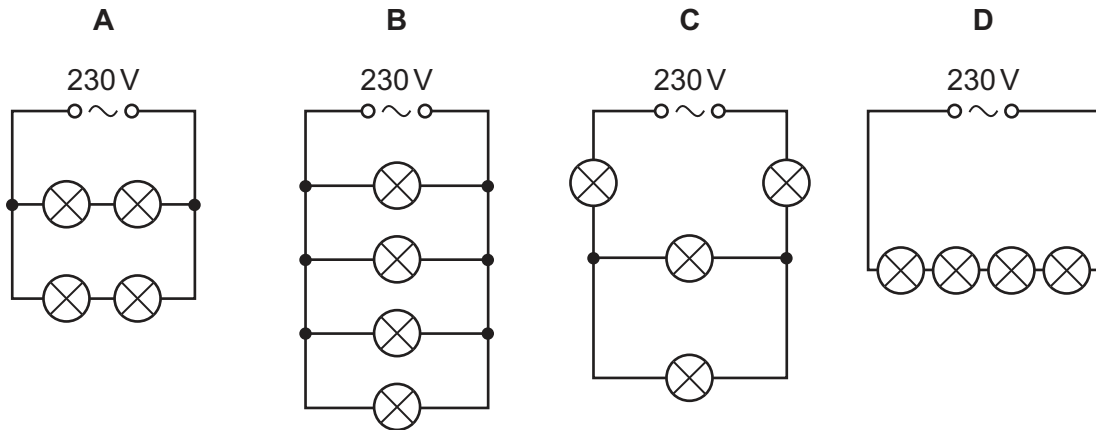

34 A step-up transformer is used before electricity is transmitted by overhead cables.

Which statement explains why the step-up transformer is used?

- A It increases the current to increase the speed at which the electricity travels.
- B It increases the current to reduce energy loss in the cables.
- C It increases the voltage to increase the speed at which the electricity travels.
- D It increases the voltage to reduce energy loss in the cables.

- 35 A current-carrying wire XY lies in the magnetic field between the two poles of a U-shaped electromagnet. A force acts on the wire XY because of the magnetic field.

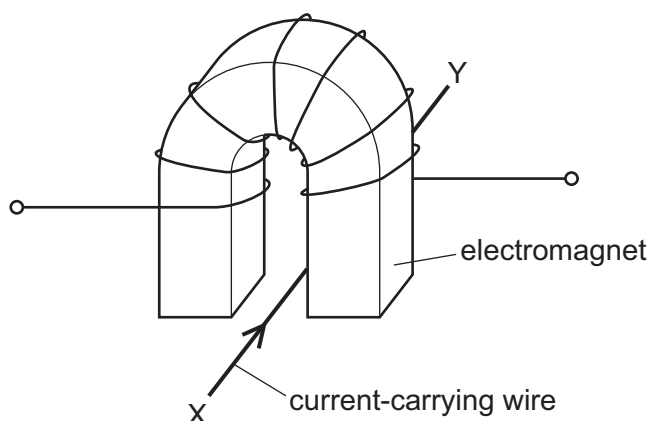

Each of the following actions is carried out separately.

- The current in the wire XY is reversed.
- The magnetic field is reversed.
- Both the current in the wire XY and the magnetic field are reversed at the same time.

How many of these actions cause the direction of the force on the wire XY to be reversed?

- A** 0                      **B** 1                      **C** 2                      **D** 3

- 36 A current-carrying coil in a magnetic field experiences a turning effect.

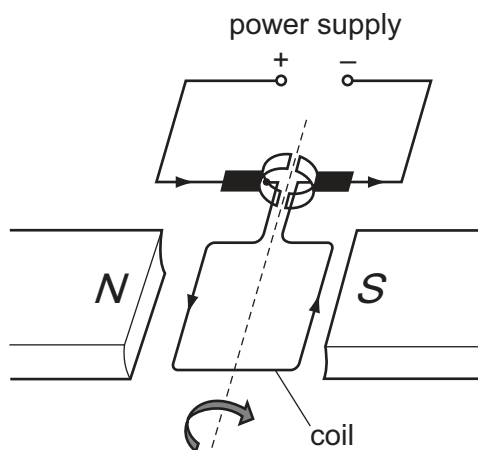

How can the turning effect be increased?

- A** Increase the number of turns on the coil.  
**B** Reduce the size of the current.  
**C** Reverse the direction of the magnetic field.  
**D** Use thinner wire for the coil.

37 The diagram shows cathode rays entering an electric field between two charged plates.

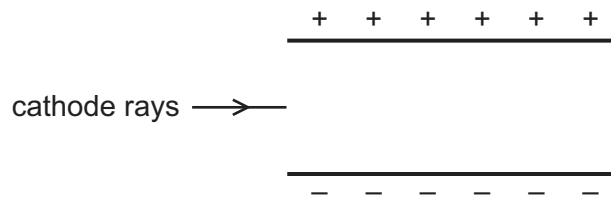

How does the path of the cathode rays change and why?

- A They move towards the negative plate because cathode rays have a negative charge.
  - B They move towards the negative plate because cathode rays have a positive charge.
  - C They move towards the positive plate because cathode rays have a negative charge.
  - D They move towards the positive plate because cathode rays have a positive charge.
- 38 The nuclide symbol for radioactive polonium is  ${}_{84}^{210}\text{Po}$ .

A nucleus of this type of polonium emits an  $\alpha$ -particle.

What is the proton number (atomic number) of the nucleus after it has emitted the  $\alpha$ -particle?

- A 82                      B 83                      C 84                      D 85

- 39 A student investigates how the radiation from a radioactive source changes with time.

The table shows the results from the detector used by the student.

time / minutes	count rate / counts per minute
0	340
2.0	180
4.0	100
6.0	60
8.0	40

The experiment is repeated by many other students, who also measure the count rate every two minutes.

The half-life of the source is known to be exactly 2.0 minutes.

Why is the measured count rate **always greater** than half the previous value?

- A Radioactive emissions occur randomly with time.
  - B The detector used is very close to the source.
  - C There is background radiation present.
  - D The radioactive source is decaying.
- 40 The nuclide notation for radium-226 is  ${}_{88}^{226}\text{Ra}$ .

How many electrons orbit the nucleus of a neutral atom of radium-226?

- A 0
- B 88
- C 138
- D 226

Permission to reproduce items where third-party owned material protected by copyright is included has been sought and cleared where possible. Every reasonable effort has been made by the publisher (UCLES) to trace copyright holders, but if any items requiring clearance have unwittingly been included, the publisher will be pleased to make amends at the earliest possible opportunity.

To avoid the issue of disclosure of answer-related information to candidates, all copyright acknowledgements are reproduced online in the Cambridge International Examinations Copyright Acknowledgements Booklet. This is produced for each series of examinations and is freely available to download at [www.cie.org.uk](http://www.cie.org.uk) after the live examination series.

Cambridge International Examinations is part of the Cambridge Assessment Group. Cambridge Assessment is the brand name of University of Cambridge Local Examinations Syndicate (UCLES), which is itself a department of the University of Cambridge.