

Centre Number	Candidate Number	Name
---------------	------------------	------

UNIVERSITY OF CAMBRIDGE INTERNATIONAL EXAMINATIONS
International General Certificate of Secondary Education

DESIGN AND TECHNOLOGY

0445/03

Paper 3 Resistant Materials

Specimen Paper for examination from 2007

Candidates answer on the Question Paper.

1 hour

No additional materials are required.

To be taken together with Paper 1 in one session of 2 hours 15 minutes.

READ THESE INSTRUCTIONS FIRST

Write your Centre Number, Candidate Number and Name in the spaces at the top of this page.

Write in dark blue or black pen.

You may use a soft pencil for any diagrams, graphs or rough working.

Do not use staples, paper clips, highlighters, glue or correction fluid.

Section A

Answer **all** questions in this section.

Section B

Answer **one** question in this section.

The total of the marks for this paper is 50.

The number of marks is given in brackets [] at the end of each question or part question.

You may use a calculator.

For Examiner's Use

Section A	
Section B	
Total	

This document consists of **14** printed pages.



UNIVERSITY of CAMBRIDGE
International Examinations

Section A

Answer **all** questions in this section.

- 1 Fig. 1 shows a stool with legs made up of thin strips of wood bent to shape.



Fig. 1

- (a) Name the type of construction used for making the legs of the stool.

..... [1]

- (b) Give **one** advantage of using this construction method.

..... [1]

- 2 Complete the sketch below to show a through housing joint.

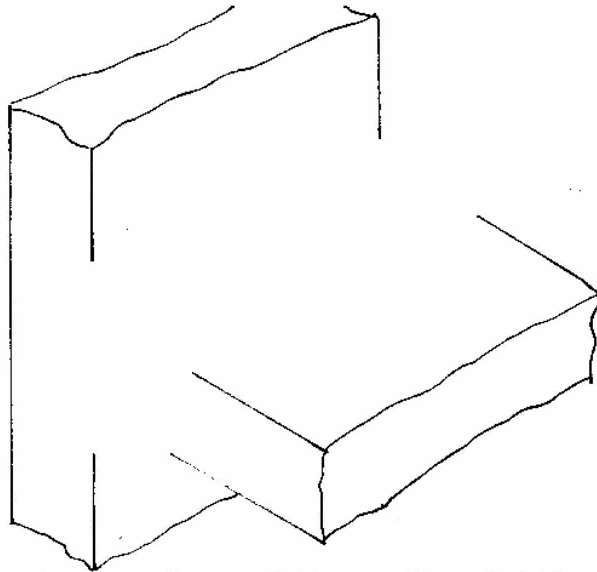

[2]

- 3 Complete the table below by stating a suitable **specific** material for each product and a reason for your choice.

Product	Specific Material	Reason for choice
Frame for a rucksack		
Rain gauge for collecting and recording rainfall		

[4]

- 4 (a) Name **one** product that has a dip-coated plastic finish.

..... [1]

- (b) Give **one** reason, other than to improve appearance, why some products are dip-coated.

..... [1]

- 5 Name the correct tool you would use to carry out each of the following processes on the mild steel sheet shown below:

- (a) marking a line parallel to the edge;

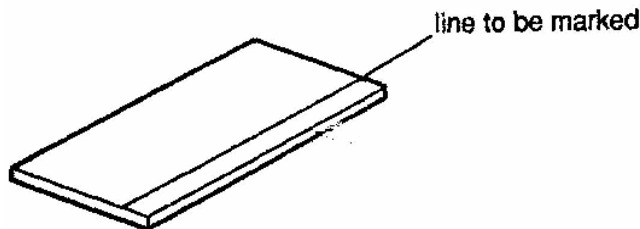

..... [1]

- (b) marking the arc;

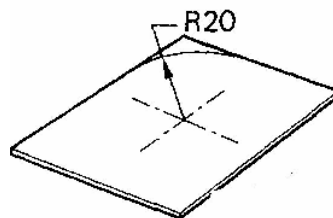

..... [1]

- (c) preventing the tool named in (b) from slipping.

..... [1]

6 Name the processes by which each of the following plastics products would be made:

(a) curtain rail,

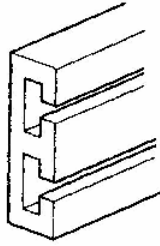

..... [1]

(b) tray.

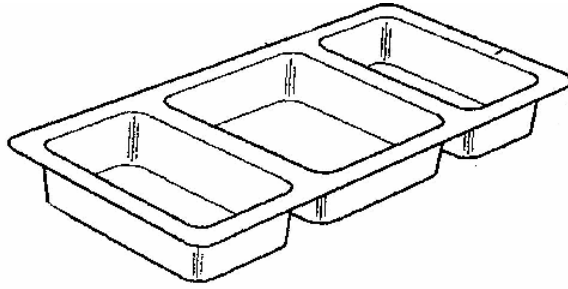

..... [1]

7 Name the appropriate file you would use to file each of the shaded surfaces on the metal shapes shown below.

(a)

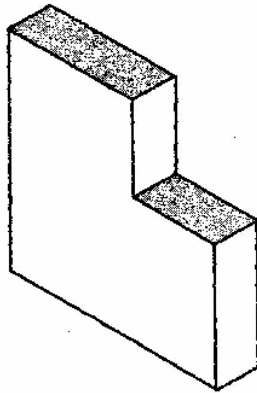

file: [1]

(b)

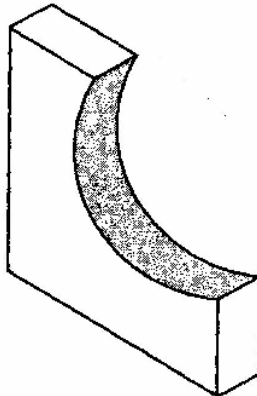

file: [1]

- 8 In each of the operations shown in Fig. 2 there is a possibility of damage to the material. Describe the damage and how it could be prevented.

Operation	Damage	Prevention
		
		

Fig. 2

[4]

- 9 Complete the sketch below to show a clearance hole and a countersunk hole.

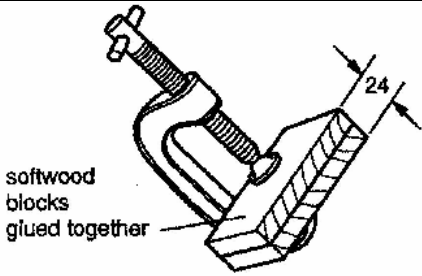
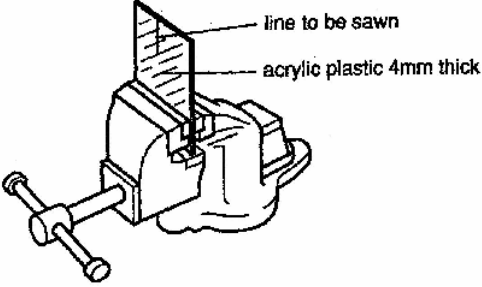
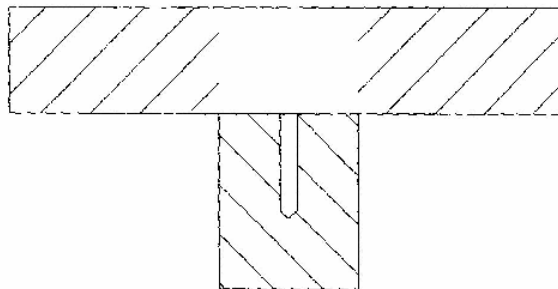

[2]

- 10 Complete the sketch to show the construction of blockboard.

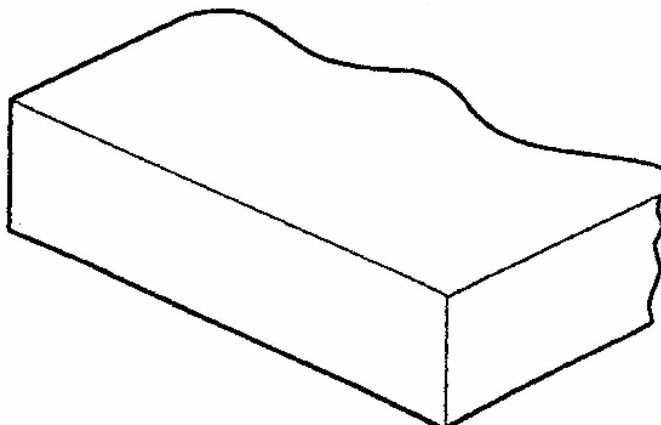

[2]

Section B

Answer **one** question in this section.

- 11 Fig. 3 shows a table to be used in a children's library. The table is supplied as flat pack ready for self-assembly.

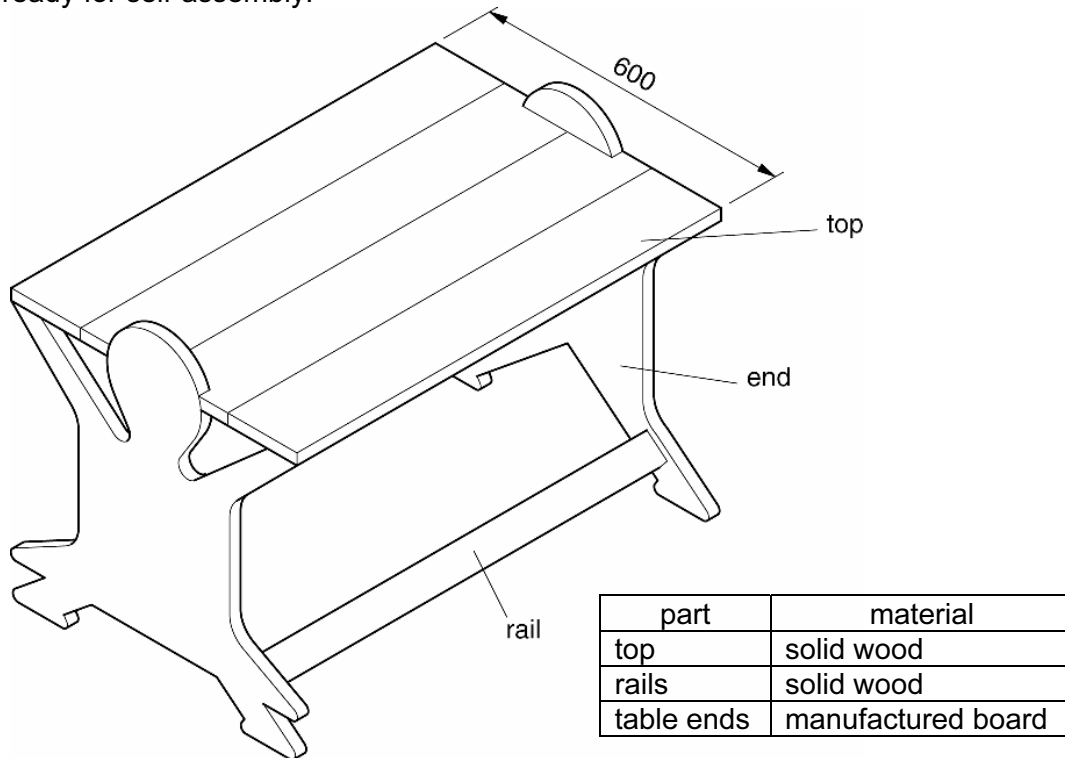

Fig. 3

- (a) State a suitable thickness for:
- (i) the solid wood table top [1]
- (ii) the manufactured board table ends [1]
- (b) (i) Name a suitable manufactured board for the table ends.
..... [1]
- (ii) Give **two** reasons why a manufactured board would be more suitable than solid wood for the table ends.
- 1 [1]
- 2 [1]
- (iii) An electric jig-saw could be used for cutting out the table end shapes. Give **two** reasons why this type of saw would be suitable.
- 1 [1]
- 2 [1]

(iv) Describe **two** safety factors that need to be considered when using a jig-saw to cut shapes out of a large sheet of manufactured board.

1 [1]

2 [1]

(c) (i) Name a suitable finish for the table top.

..... [1]

(ii) Give **one** reason for your choice.

..... [1]

(d) Fig. 4 shows the solid wood top made from four separate pieces of wood.

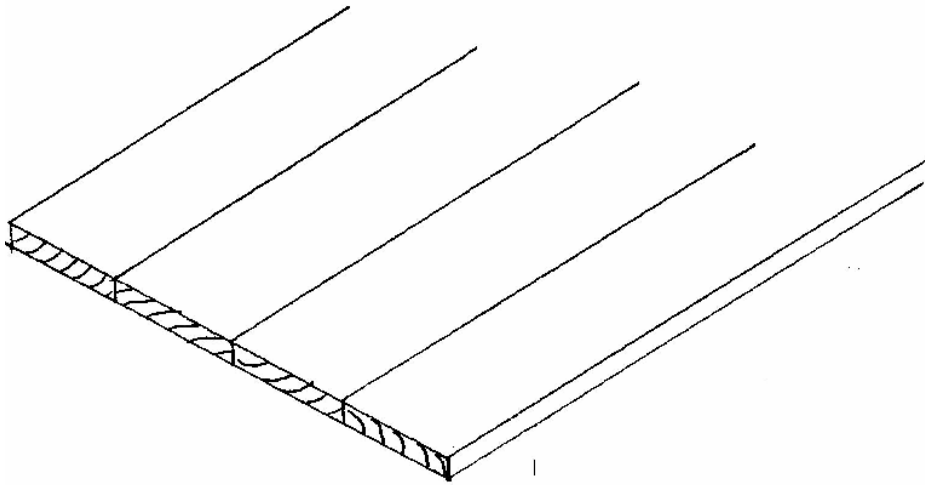

Fig. 4

(i) Explain why the pieces are arranged in this way.

.....
.....
..... [2]

(ii) Use notes and sketches to show how sash cramps could be used to hold the four pieces of solid wood together when gluing up.

[3]

- (iii) Name a suitable adhesive you could use to join the four pieces of solid wood for the table top.

..... [1]

- (e) (i) Use notes and sketches to show how the wooden rails could be attached to the table ends by means of suitable knock-down (K-D) fittings.

[4]

- (ii) An alternative design for the rails uses a rectangular steel tube shown below. Sketch a suitable method of joining the steel tube to the table ends. Your method must allow the rail and table ends to be disassembled.

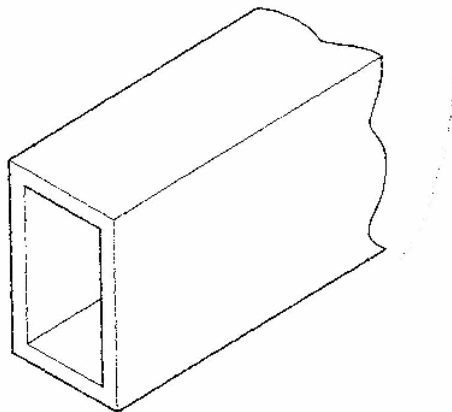

[4]

12 Fig. 5 shows a design for a desk tidy made from a single piece of acrylic sheet.

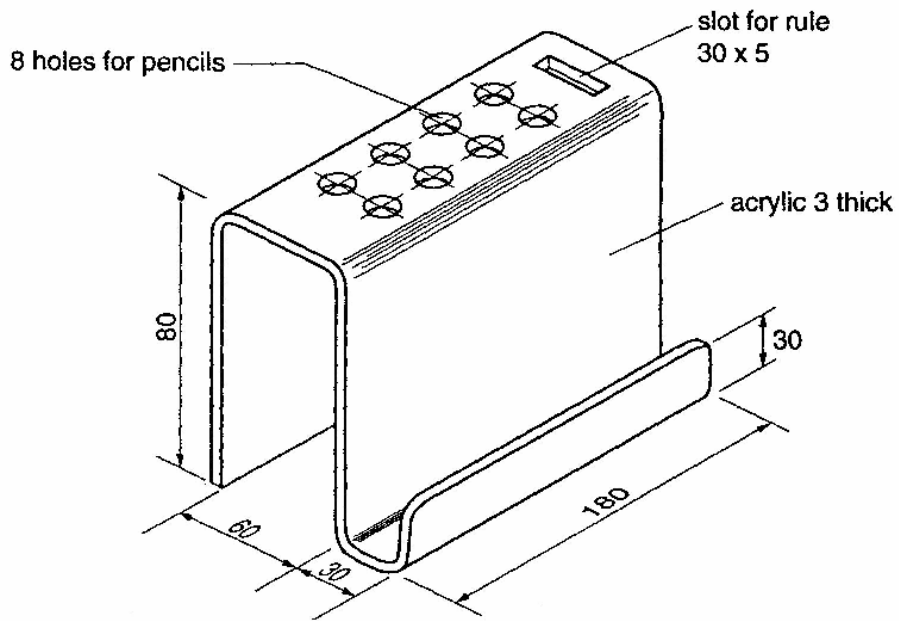

Fig. 5

- (a) Use notes and sketches to show how the desk tidy could be marked out on one piece of plastic. Draw clearly the slot for the rule in the correct position. **Do not** draw the positions for the holes.

[6]

(b) Fig. 6 shows the marked out slot for the rule.

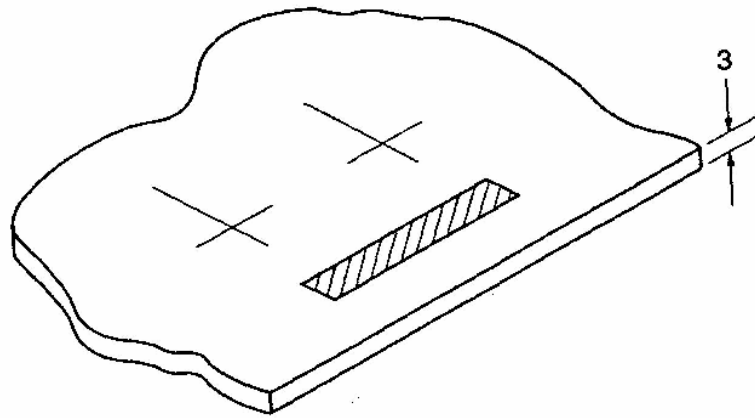

Fig. 6

Complete the table below by describing the processes and naming the tools or equipment required to produce the slot in the acrylic plastic.

Stage	Process	Tools/equipment
1	Mark out the slot on plastic	
2		
3		
4	Clean up the edges of the slot	

[6]

- (c) Use notes and sketches to show how the four bends could be produced in the sheet of plastic.

Include the following details:

- the method of heating the plastic;
- the use of jigs or formers;
- the means of holding the plastic in position while it cools down.

[8]

- (d) In use it was found that the pencils and rule fell through the desk tidy when it was lifted. Use notes and sketches to show additions/modifications to the design to prevent this from happening.

[5]

13 Fig. 7 shows a trailer to be pulled behind a bicycle by means of a towing bar made from mild steel tube.

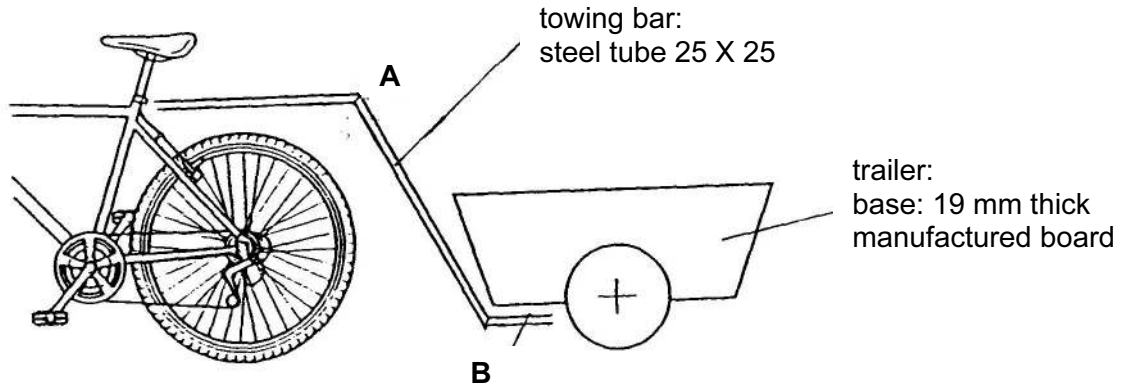

Fig. 7

(a) State **two** properties of mild steel that make it suitable for the towing bar.

1 [1]

2 [1]

(b) The table below gives some of the stages and processes involved in making the towing bar.

Complete the table.

Stage	Process	Tools/equipment
1	Mark the tube to correct lengths	
2	Hold the tube so that it can be cut	
3	Cut the tube	
4	Square the ends of the tube	

[4]

(c) Explain the purpose of the following items of equipment used in the preparation and brazing of the mild steel tube:

(i) emery cloth
.....
..... [2]

(ii) flux
.....
..... [2]

(iii) brazing rod
.....
..... [2]

(d) Describe **one** safety precaution you would need to take when brazing the mild steel tube.
..... [1]

(e) Give **two** reasons why the mild steel tube used for the towing bar would need to be painted.

1 [1]

2 [1]

(f) Fig. 8 shows the joint at **A**.
Use notes and sketches to show how the joint could be strengthened.
Include details of materials used and methods of joining.

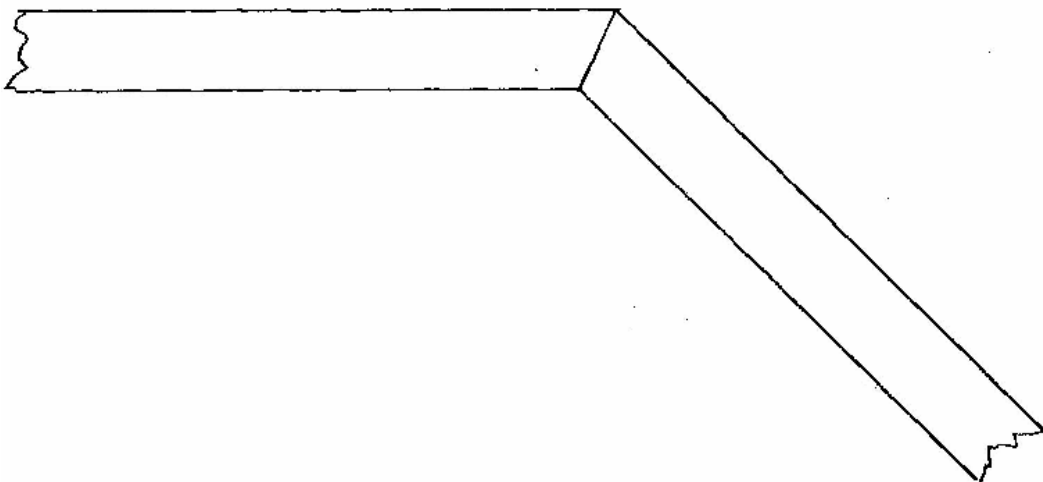

Fig. 8

[4]

- (g) The end of the towing bar is to be fixed to the underside of the trailer.
Use notes and sketches to show how the end of the tube at **B** could be modified so that it could be fitted securely to the trailer.

Include the following in your design:

- details of additional materials used;
- the method of fixing between the tube and the underside of the trailer.

[6]

Permission to reproduce items where third-party owned material protected by copyright is included has been sought and cleared where possible. Every reasonable effort has been made by the publisher (UCLES) to trace copyright holders, but if any items requiring clearance have unwittingly been included, the publisher will be pleased to make amends at the earliest possible opportunity.

University of Cambridge International Examinations is part of the University of Cambridge Local Examinations Syndicate (UCLES), which is itself a department of the University of Cambridge.