



**Cambridge Assessment International Education**  
Cambridge International General Certificate of Secondary Education

CANDIDATE  
NAME

CENTRE  
NUMBER

--	--	--	--	--

CANDIDATE  
NUMBER

--	--	--	--



**DESIGN AND TECHNOLOGY**

**0445/33**

Paper 3 Resistant Materials

**October/November 2019**

**1 hour**

Candidates answer on the Question Paper.

No Additional Materials are required.

**READ THESE INSTRUCTIONS FIRST**

Write your centre number, candidate number and name on all the work you hand in.

Write in dark blue or black pen.

You may use an HB pencil for any diagrams, graphs or rough working.

Do not use staples, paper clips, glue or correction fluid.

DO **NOT** WRITE IN ANY BARCODES.

**Section A**

Answer **all** questions in this section.

**Section B**

Answer **one** question in this section.

You may use a calculator.

At the end of the examination, fasten all your work securely together.

The number of marks is given in brackets [ ] at the end of each question or part question.

The total of the marks for this paper is 50.

This document consists of **20** printed pages.

**Section A**

Answer **all** questions in this section.

- 1 Fig. 1 shows a cycle helmet. The outer and inner shells are made from different plastics.

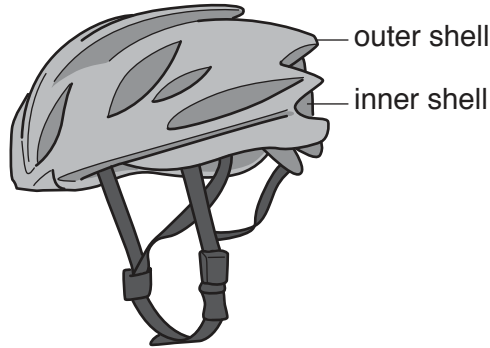
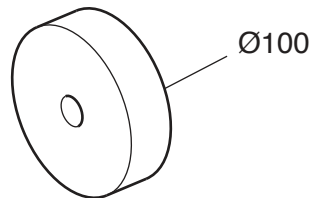

**Fig. 1**

Give **two** properties required of the plastics used to make the cycle helmet.

- 1 .....
- 2 ..... [2]

- 2 Fig. 2 shows a small wheel. The wheel could be made from wood, metal or plastic.



**Fig. 2**

Name a suitable manufacturing process used to produce the wheel when made from:

- wood  
.....
- metal  
.....
- plastic.  
..... [3]

3 Fig. 3 shows two pieces of wood being glued together.

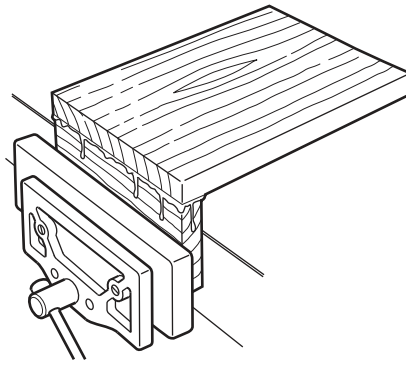

Fig. 3

Draw on Fig. 3 to show how the glued joint could be strengthened by dovetail nailing. [2]

4 Fig. 4 shows a saucepan.



Fig. 4

(a) Name a thermosetting plastic that could be used for the handle.

.....

Give a reason for your choice.

.....

[2]

(b) Name a ferrous alloy that could be used for the saucepan body.

.....

Give a reason for your choice.

.....

[2]

5 Fig. 5 shows three pre-drilled holes to take a screw.

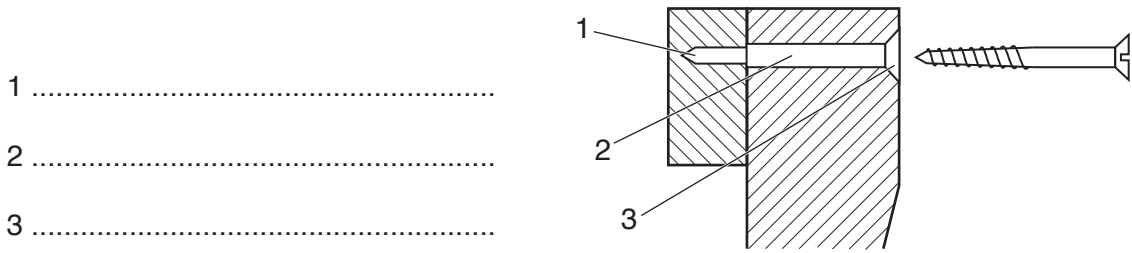

Fig. 5

Select from the list below the correct name for each hole.

- countersunk hole      stopped hole      angled hole      pilot hole      clearance hole [3]

6 Fig. 6 shows a board made from hardwood. The board needs to be seasoned.

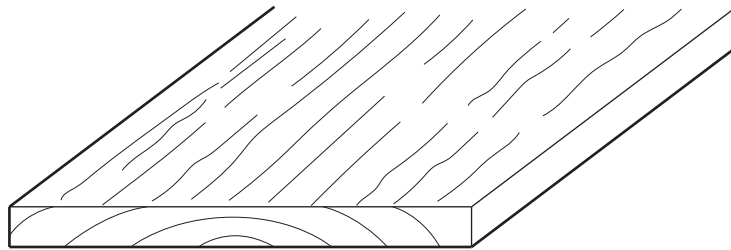

Fig. 6

Draw on Fig. 6 to show what could happen to the shape of the board if it was incorrectly seasoned. [1]

7 Fig. 7 shows a wheelbarrow. The mild steel body of the wheelbarrow is galvanised.

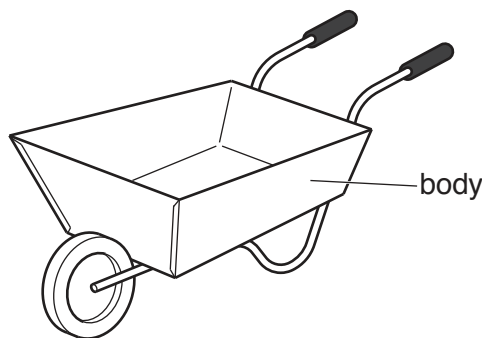

Fig. 7

(a) State what is meant by the term 'galvanised'.  
 ..... [1]

(b) State why it is necessary for the body of the wheelbarrow to be galvanised.  
 ..... [1]

8 Fig. 8 shows a child's push-along go-kart.

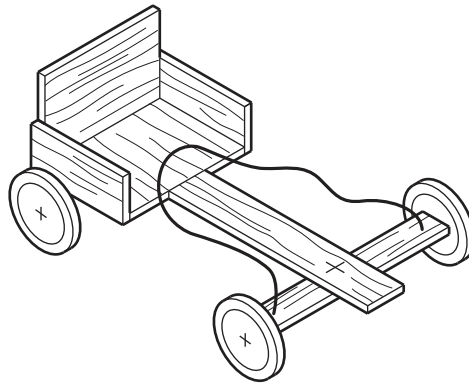

Fig. 8

Give **two** examples of anthropometric data used in the design of the go-kart.

1 .....

2 .....

[2]

9 Fig. 9 shows a length of wood set up on a woodturning lathe.

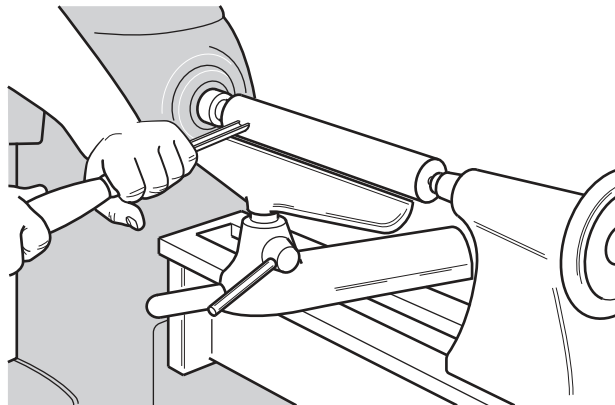

Fig. 9

(a) Name the method of woodturning shown in Fig. 9.

..... [1]

(b) Fig. 10 shows a length of wood ready to be set up on the woodturning lathe.

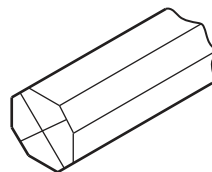
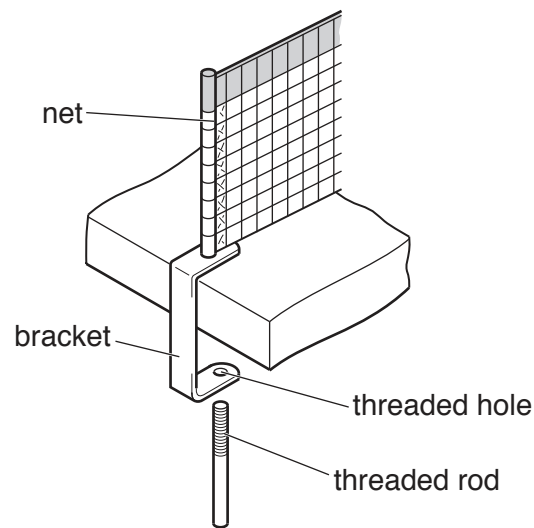

Fig. 10

Give **one** reason why the corners of the wood have been removed.

..... [1]

10 Fig. 11 shows an incomplete metal bracket used to support a net on a table-tennis table.



**Fig. 11**

(a) Name the tool that has been used to cut the thread in the hole on the bracket.

..... [1]

(b) Name the tool that has been used to cut the thread on the rod.

..... [1]

(c) In use, the threaded rod is difficult to tighten by hand.

Use sketches and notes to show how the threaded rod could be made easier to tighten.

[2]

## Section B

Answer **one** question in this section.

- 11 Fig. 12 shows a desk tidy made from 4 mm thick plywood. The desk tidy will be batch produced in quantity.

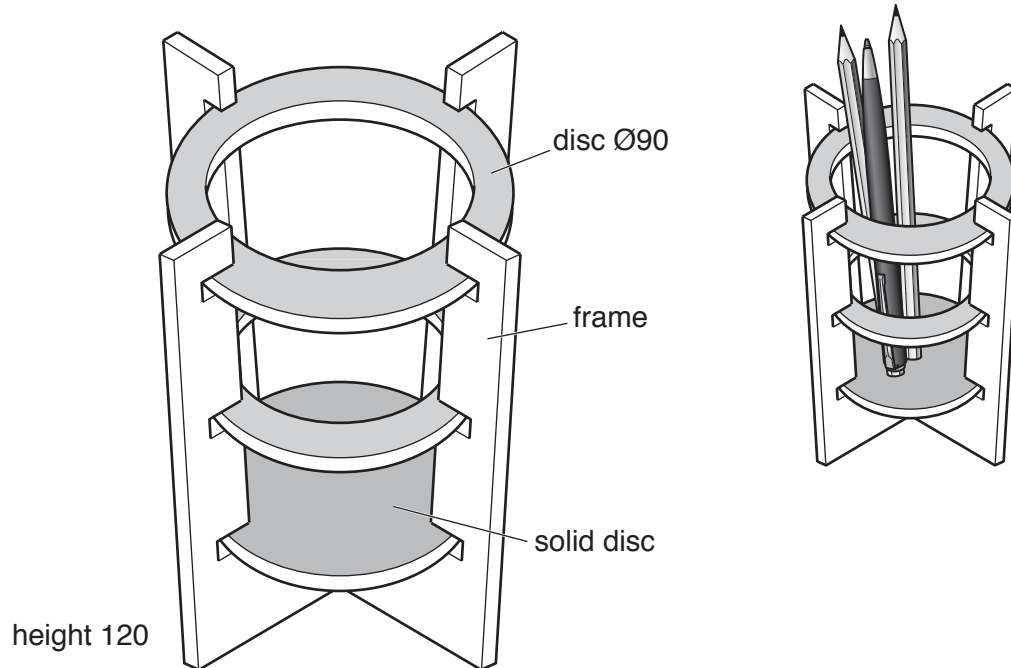
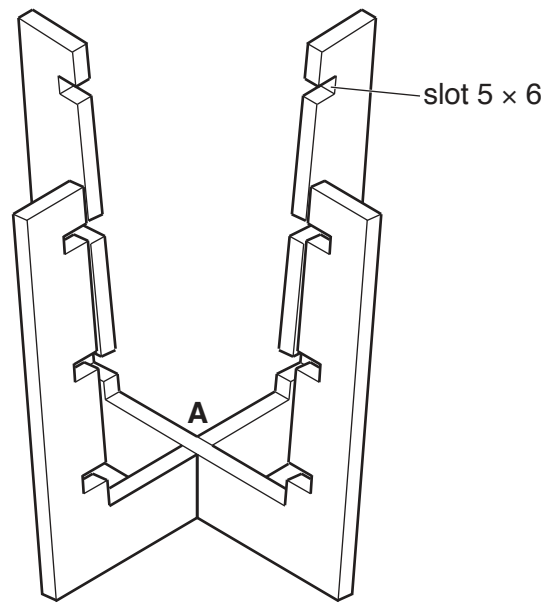

Fig. 12

- (a) Use sketches and notes to show the construction of 4 mm thick plywood to explain why it is suitable for the desk tidy.

[3]

- (b) Fig. 13 shows details of the two frames of the desk tidy. The frames are joined at **A** by means of a cross-halving joint.



**Fig. 13**

Draw the cross-halving joint used at **A**.



- (c) Fig. 14 shows one disc marked out, ready to be cut to shape. The  $\text{\O}60$  hole has been drilled in the disc.

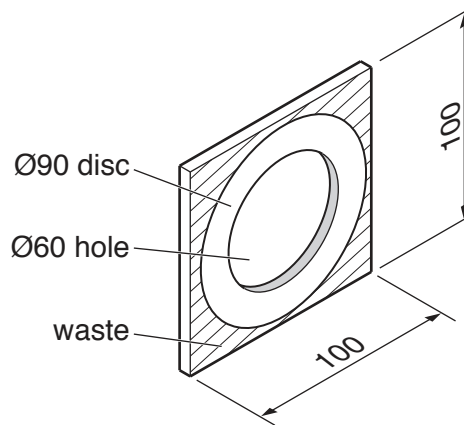

Fig. 14

- (i) The  $\text{\O}60$  hole has been drilled using the tool shown below. Give the correct name of the tool shown.



..... [1]

- (ii) Describe how the  $\text{\O}90$  disc could be cut out of a sheet of 4 mm thick plywood and finished accurately.

.....  
 .....  
 ..... [2]

- (d) Fig. 15 shows a template that could be used to mark out a large quantity of frames.

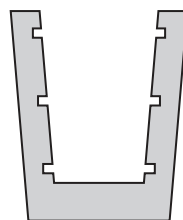

Fig. 15

Give **one** reason why the template would need to be made from a resistant material such as wood, metal or plastic.

.....  
 ..... [1]

(e) The desk tidy could be designed using CAD.

Give **three** advantages, other than speed, of using CAD rather than traditional drawing methods to design the desk tidy.

- 1 .....
- 2 .....
- 3 .....

[3]

(f) The desk tidy needs to be modified so that it can rotate as shown in Fig. 16.

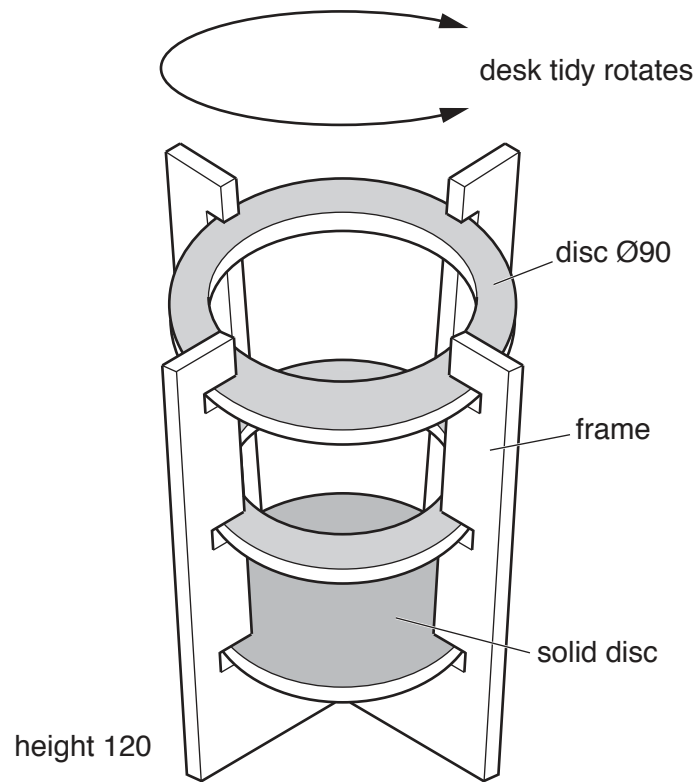

Fig. 16

Use sketches and notes to show how the desk tidy could be modified so that it could rotate. Include details of materials and constructions used.

[6]

(g) The parts of the desk tidy will be glasspapered then spray painted.

(i) Explain why it is necessary to use different grades of glasspaper to prepare the surfaces for the spray paint.

.....  
.....  
..... [2]

(ii) Give **two** safety precautions that must be taken when spray painting.

1 .....  
2 ..... [2]

(h) Describe **two** quality control checks that would be carried out **during** the manufacture of a batch of desk tidies.

1 .....  
2 ..... [2]

12 Fig. 17 shows a basic design for a toothbrush holder made from 4 mm thick acrylic.

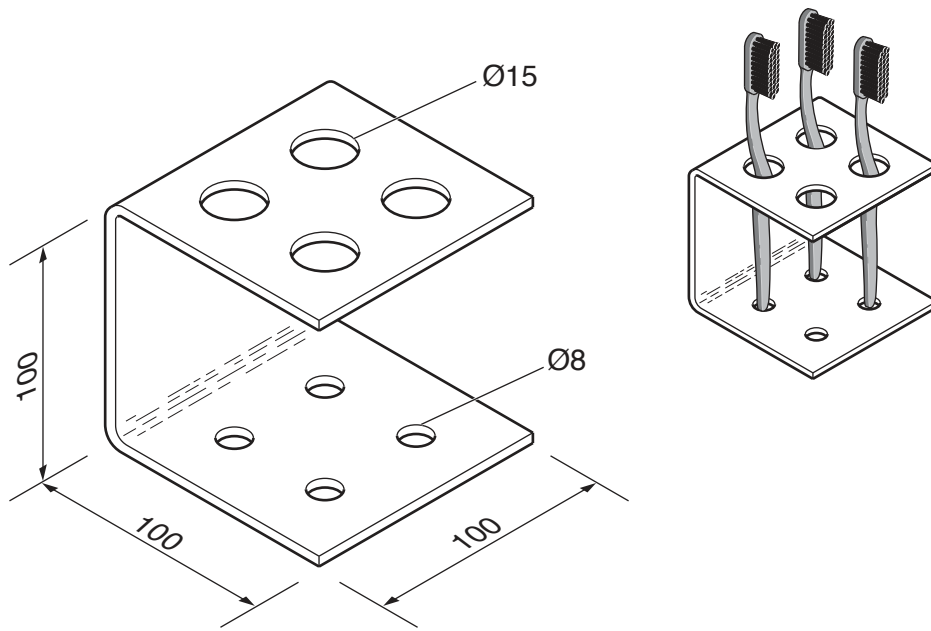

Fig. 17

(a) Give **two** specification points for the toothbrush holder in addition to the one given below.  
*The toothbrush holder must:*

1 hold up to four toothbrushes

2 .....

3 .....

[2]

(b) Fig. 18 shows the development (net) of the toothbrush holder marked out showing the bend lines and centres for Ø15 and Ø8 holes to be drilled.

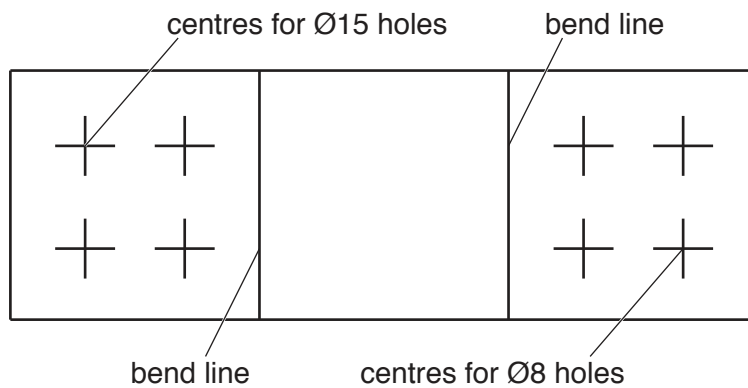

Fig. 18

(i) Give **one** reason why a marker pen would be used to mark the bend lines rather than a scribe.

..... [1]

- (ii) Use sketches and notes to show how the acrylic sheet could be held when the Ø15 holes are drilled.

[3]

- (c) Acrylic is a thermoplastic. Explain a benefit of using a thermoplastic for the toothbrush holder.

.....  
.....  
..... [2]

- (d) The edges of the acrylic toothbrush holder will be self-finished.

- (i) Name the method of filing that would be used to finish the edges.

..... [1]

- (ii) Explain why it is necessary to use different grades of wet and dry (silicon carbide) paper to finish the edges.

.....  
.....  
..... [2]

- (e) A batch of 40 toothbrush holders is to be made in a school workshop.  
Use sketches and notes to show:
- (i) a design for a drilling jig that could be used to speed up production

[3]

- (ii) how the acrylic shape could be bent accurately to the required shape.

[3]

- (f) Use sketches and notes to show a modification to the design of the toothbrush holder shown in Fig. 17 so that the tube of toothpaste shown below could be stored.

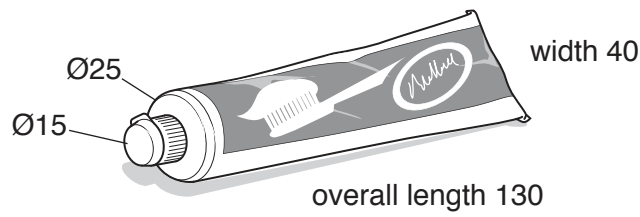

[4]

- (g) Fig. 19 shows a commercially produced toothbrush holder made from stainless steel.

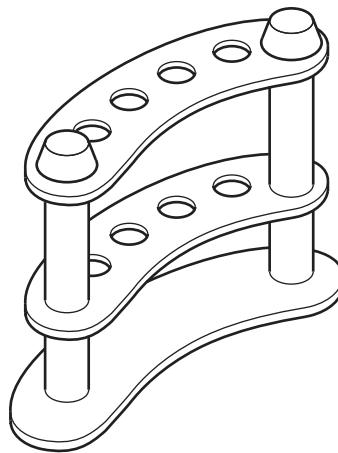

Fig. 19

- (i) Give **two** benefits of using stainless steel for products that will be used in a bathroom.

1 .....

2 .....

[2]

- (ii) Explain why, other than the cost of the material, the stainless steel toothbrush holder could be expensive to manufacture.

.....

.....

..... [2]

13 Fig. 20 shows a wall-mounted cycle rack made from 19 mm thick manufactured board.

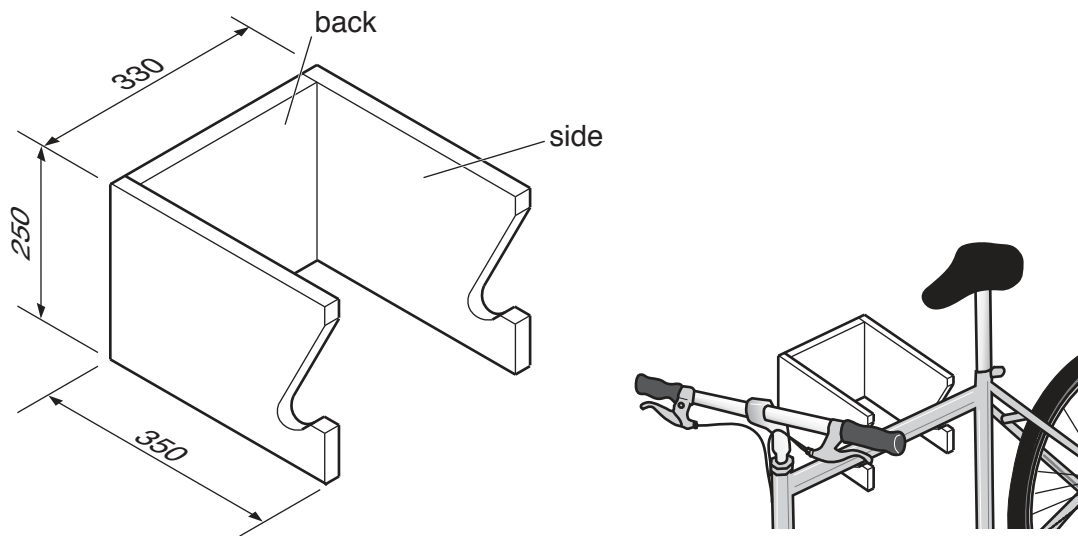

Fig. 20

(a) Give **two** advantages of making the cycle rack from a manufactured board rather than a solid wood.

1 .....

2 .....

[2]



(b) Fig. 21 shows one side marked out ready to be cut to shape.

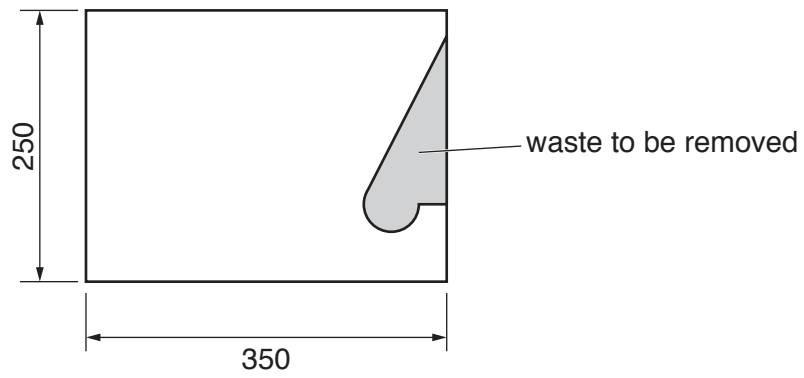
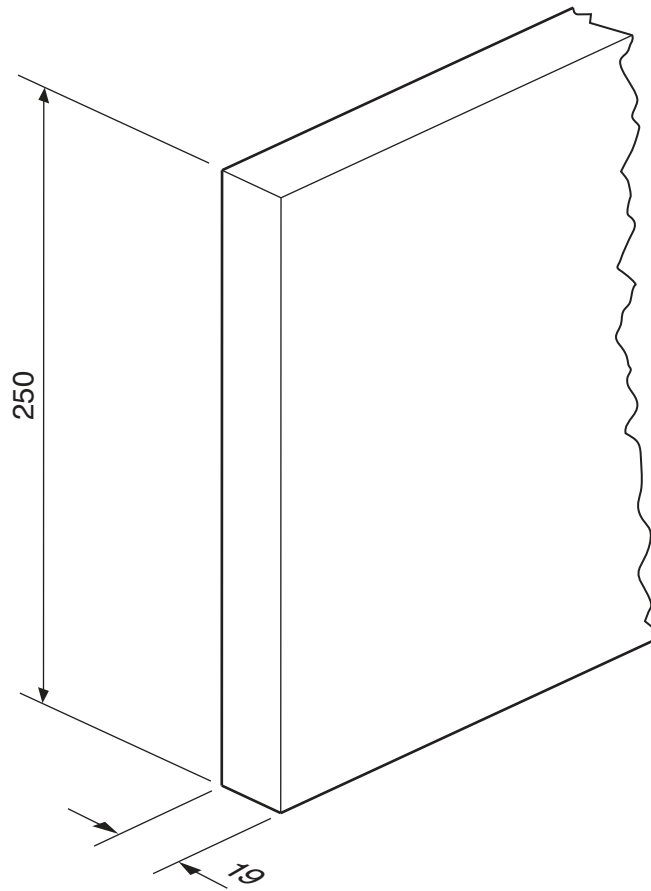

**Fig. 21**

Use sketches and notes to show how the waste could be removed and the edges made smooth. Name **all** the tools and equipment used.

[4]

- (c) The sides will be joined to the back using four  $\text{Ø}9$  dowels.  
Fig. 22 shows part of the back of the cycle rack.



**Fig. 22**

- (i) Draw on Fig. 22 to show the positions and spacing of the four dowels. [2]  
(ii) Design a drilling jig that could be used on the sides and back to speed up production.

(d) Fig. 23 shows views of a different design of a wall-mounted cycle rack made from 2mm thick mild steel sheet.

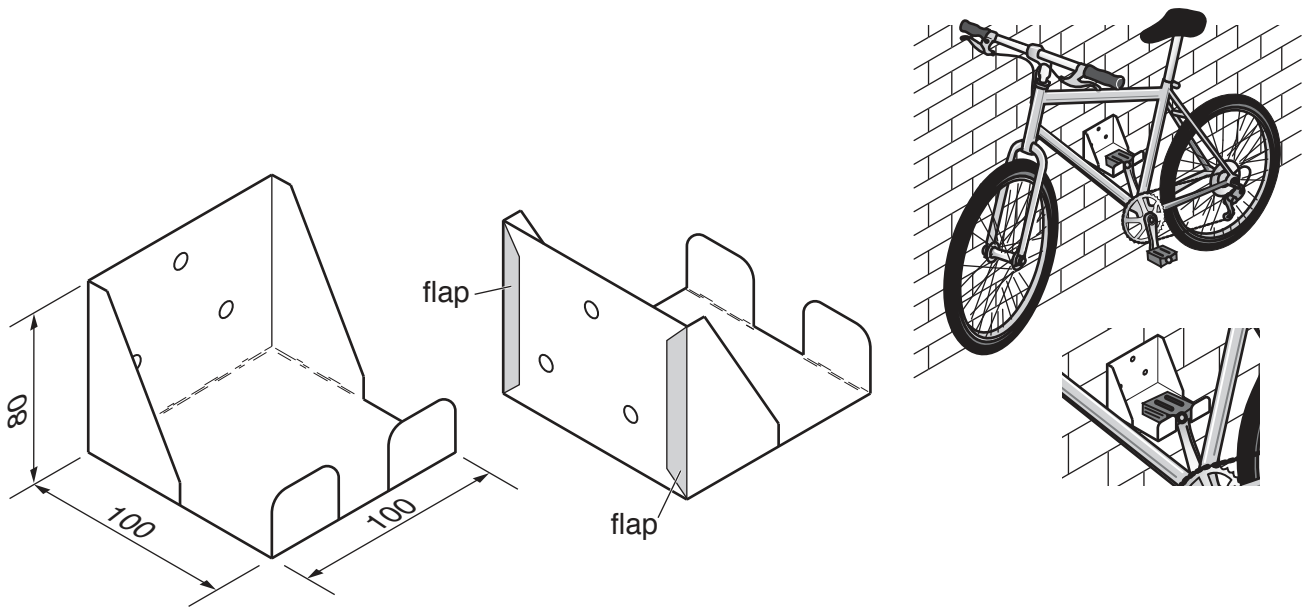

Fig. 23

Give **one** benefit of making the cycle rack from mild steel sheet.

..... [1]

(e) Give **two** reasons why a designer would make computer-generated models of the cycle racks.

1 .....

2 .....

[2]

(f) The development (net) of the cycle rack is shown below.

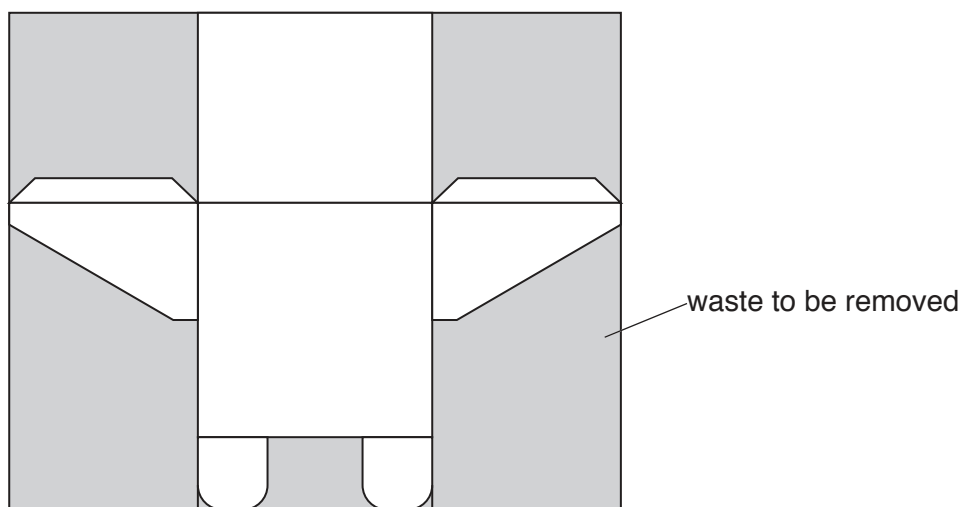

Circle from the list below **two** tools that could be used to cut out the development (net).

pad saw

bench shears

back saw

panel saw

tinsnips

[2]

(g) The flaps will be joined permanently to the back of the cycle rack shown in Fig. 23.

(i) Name a permanent method of joining the flaps to the back that uses heat.

..... [1]

(ii) Name a permanent method of joining the flaps to the back without the use of heat.

..... [1]

(h) Fig. 24 shows two screws that could be used to fix the sheet metal cycle rack to a wall.

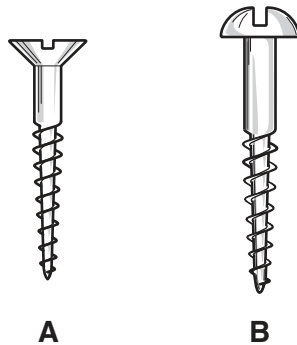

Fig. 24

(i) Choose which of the screws, **A** or **B**, would be more suitable. Give a reason for your choice.

Chosen screw .....

Reason .....

..... [2]

(ii) Describe **two** precautions, other than wearing eye protection, that should be taken when drilling sheet metal.

1 .....

2 .....

[2]

(i) Explain which of the two cycle racks would be more expensive to manufacture in quantity.

.....

.....

..... [2]

Permission to reproduce items where third-party owned material protected by copyright is included has been sought and cleared where possible. Every reasonable effort has been made by the publisher (UCLES) to trace copyright holders, but if any items requiring clearance have unwittingly been included, the publisher will be pleased to make amends at the earliest possible opportunity.

To avoid the issue of disclosure of answer-related information to candidates, all copyright acknowledgements are reproduced online in the Cambridge Assessment International Education Copyright Acknowledgements Booklet. This is produced for each series of examinations and is freely available to download at [www.cambridgeinternational.org](http://www.cambridgeinternational.org) after the live examination series.

Cambridge Assessment International Education is part of the Cambridge Assessment Group. Cambridge Assessment is the brand name of the University of Cambridge Local Examinations Syndicate (UCLES), which itself is a department of the University of Cambridge.