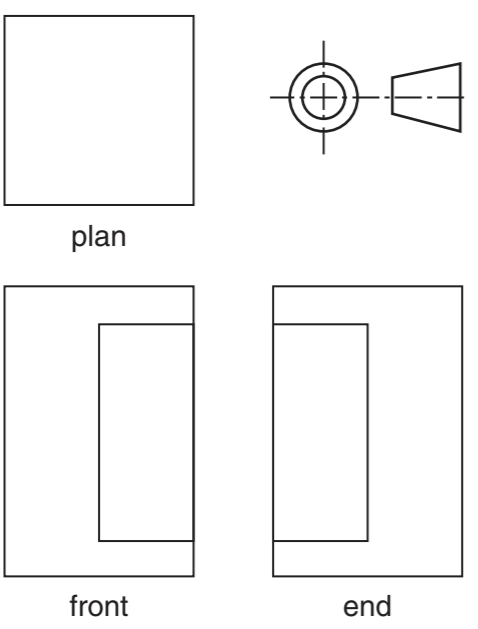
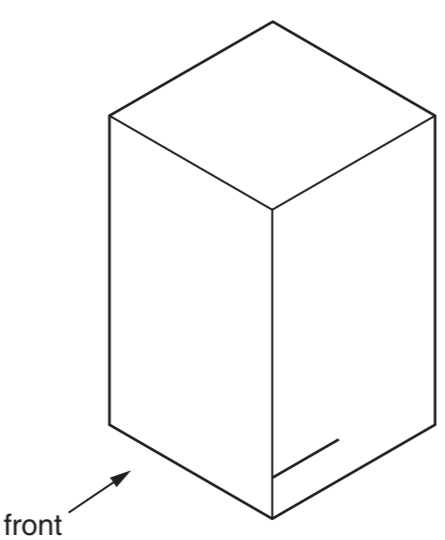
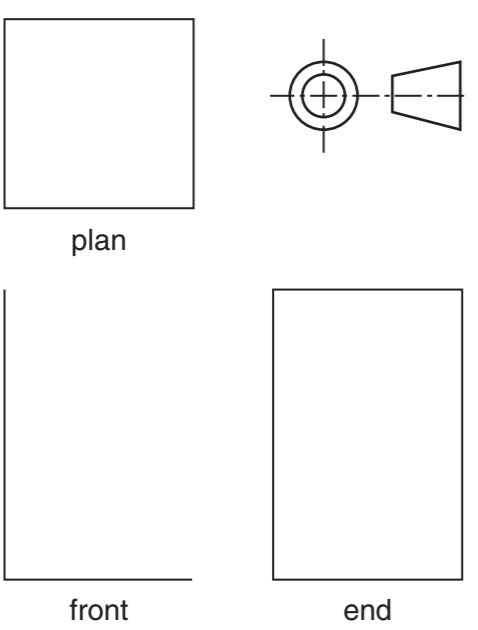
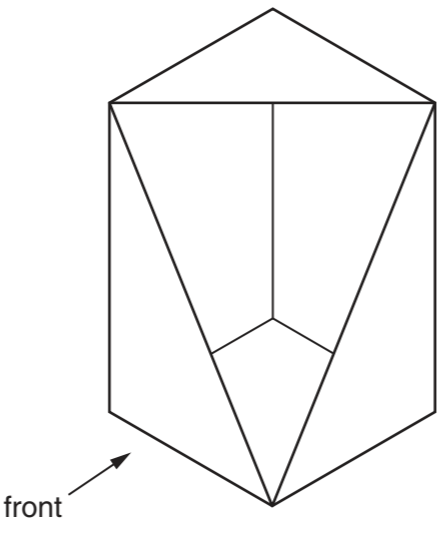

Section A

Answer **all** questions in this section.

A1 The drawings below show two designs for card packages with clear plastic windows. In the spaces provided complete:

- (a) the isometric drawing of design **A**; [5]
- (b) the orthographic views of design **B**. [4]

	orthographic views	isometric
A	 <p>plan</p> <p>front</p> <p>end</p>	 <p>front</p>
B	 <p>plan</p> <p>front</p> <p>end</p>	 <p>front</p>

A2 (a) (i) Name a plastic that could be used for the windows.

..... [1]

(ii) Give two reasons why the material is suitable for this use.

1. [1]

..... [1]

2. [1]

..... [1]

(b) Use a sketch and notes to show a method of fixing a window in place on a card package. [2]

For
Examiner's
use

0445/21 Oct/Nov 2016 **1 hour**
© UCLES 2016 DC (KN/FD) 136123/5 R

Centre Number Candidate Number Candidate Surname Other Names **[Turn over**

A3 Design **A** will be used as a package for a metal cup. Orthographic views of the metal cup are shown below.

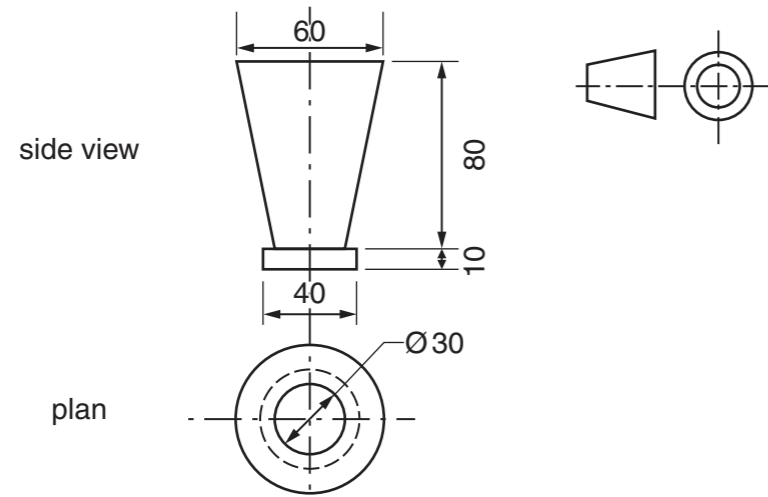

(a) On the centre lines below draw a full-size planometric view of the metal cup. [6]

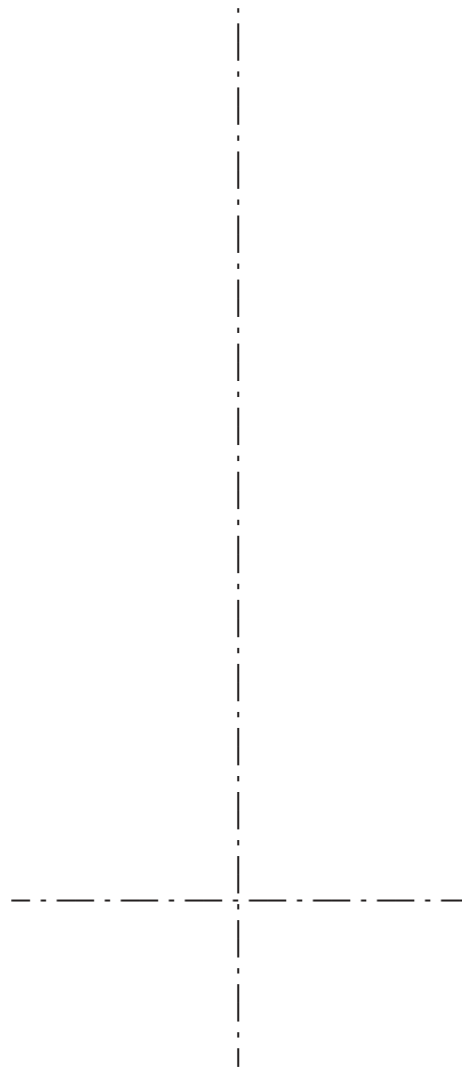

(b) Design **B** is available in three different colours. The sales of each colour in 2015 are shown below.

	red	blue	yellow
sales	800	400	600

On the centre lines below draw a pie chart to show the sales of each colour. [5]

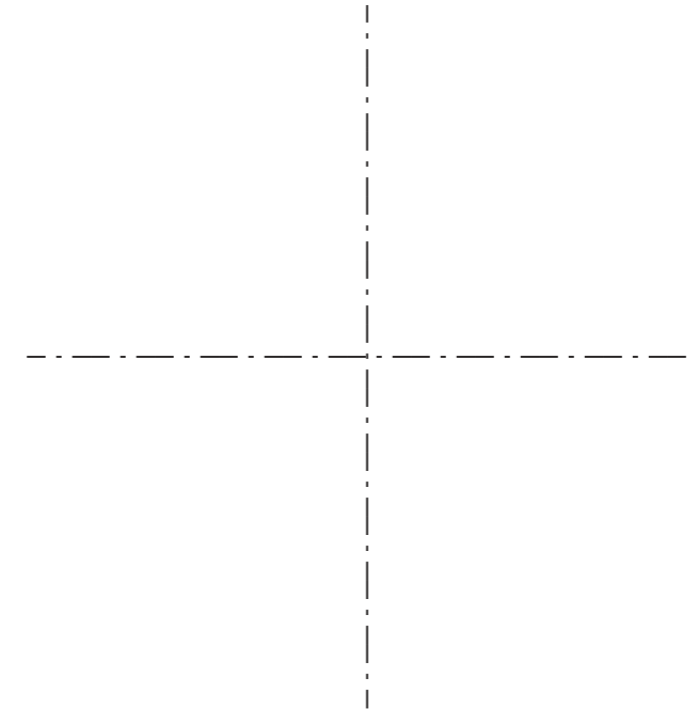

Section B
Answer **either** question **B4** or **B5**.

B4 Orthographic views of a perfume bottle are shown on the right.

(a) Complete the estimated two-point perspective drawing below of the perfume bottle. [15]

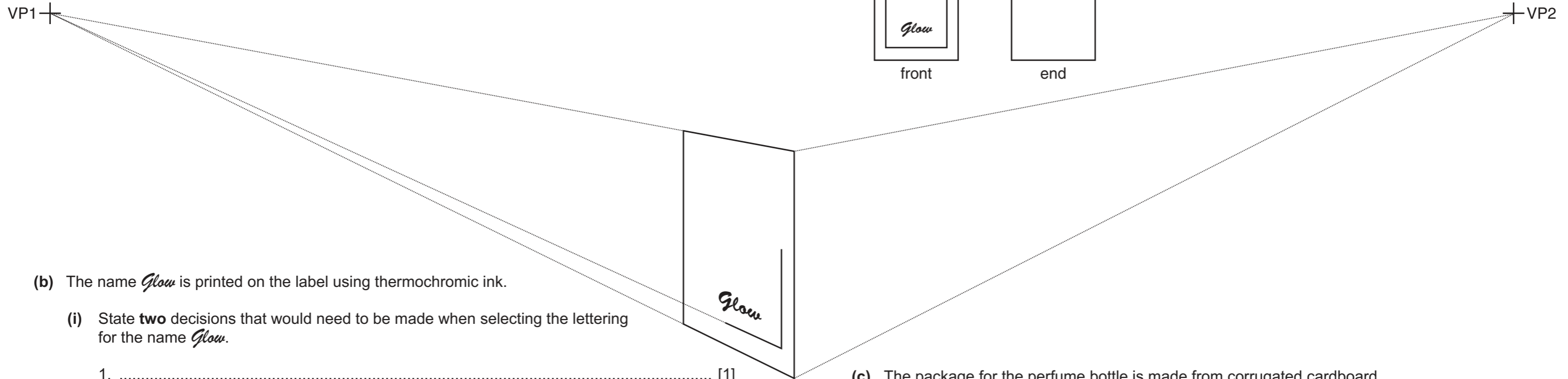
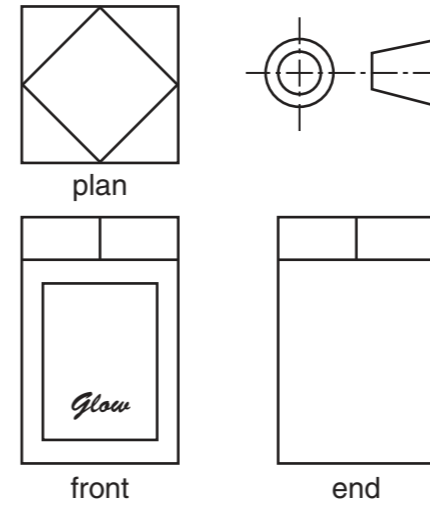

(b) The name *Glow* is printed on the label using thermochromic ink.

(i) State **two** decisions that would need to be made when selecting the lettering for the name *Glow*.

1. [1]

2. [1]

(ii) In the space below use a sketch and notes to explain how thermochromic ink would add interest to the label. [3]

(c) The package for the perfume bottle is made from corrugated cardboard.

(i) Draw in the space below a sectional view of corrugated cardboard. [3]

(ii) State **two** properties of corrugated cardboard that make it suitable as packaging for the perfume bottle.

1. [1]

2. [1]

For
Examiner's
use

0445/21 Oct/Nov 2016 **1 hour**
© UCLES 2016 DC (KN/FD) 136123/5 R

Centre Number Candidate Number Candidate Surname Other Names **[Turn over]**

B5 A sketch of a sports company logo is shown below.

(a) Complete the enlargement of the logo. [12]

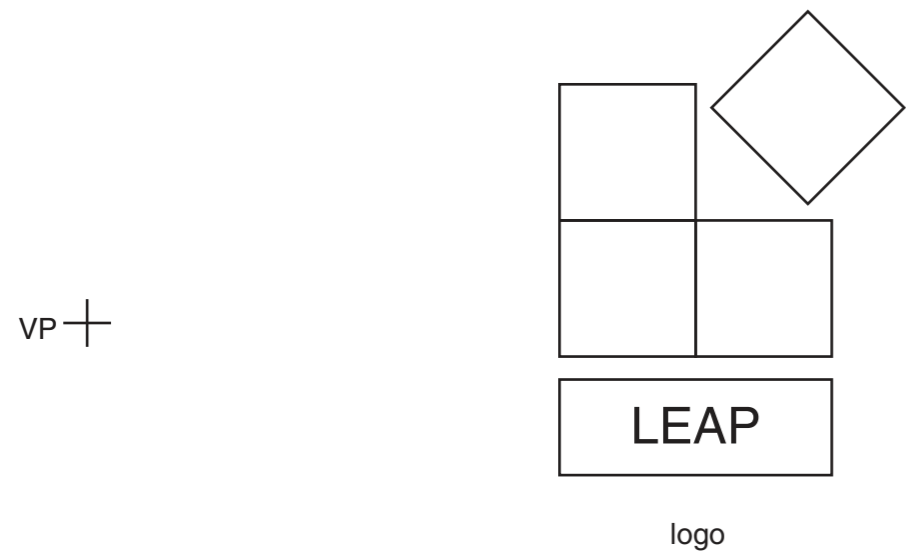

(c) A three-dimensional version of the sports logo is shown below. Apply thick and thin line technique to enhance the drawing of the logo below. [3]

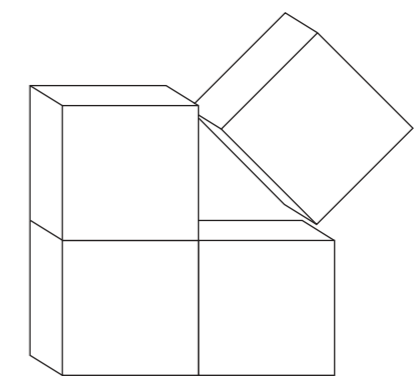

(b) The logo is to be screen-printed on a tee-shirt. Use sketches and notes to describe the process of screen printing. [7]

(d) Objects are frequently drawn to scale. Complete the table below to show scales that are commonly used in drawing. [3]

scale	object	drawing
1:1	100 mm
1:2	300 mm
5:1	100 mm