

Section A

Answer **all** questions in this section.

A logo for a holiday company is shown below.

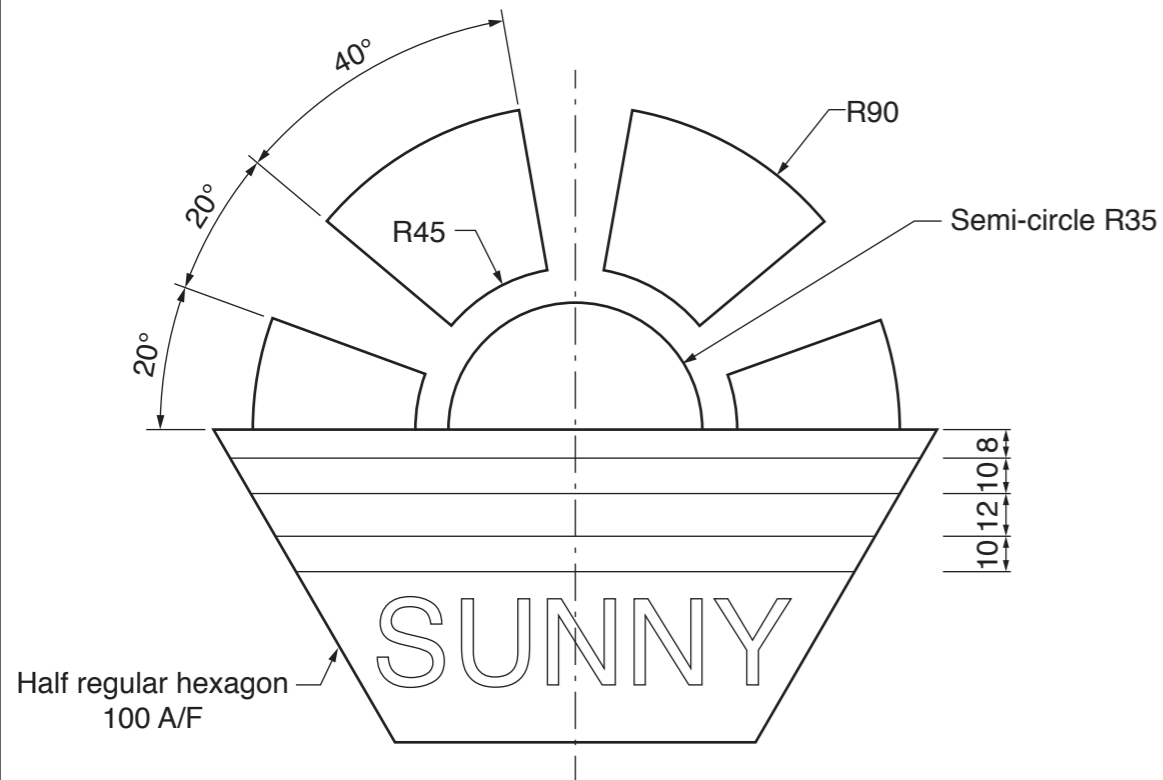

A1 Complete the full size view of the logo in the space provided to the right by drawing:

- (a) the setting sun design; [6]
- (b) the lower half hexagon and horizontal lines; [4]
- (c) the SUNNY lettering. [3]

A2 (a) The logo is to be created and stored on a computer as a Bitmap image.

(i) Name **one** other suitable file type for storing the image.
[1]

(ii) Describe **one** advantage of vector images compared to bitmap images.

[2]

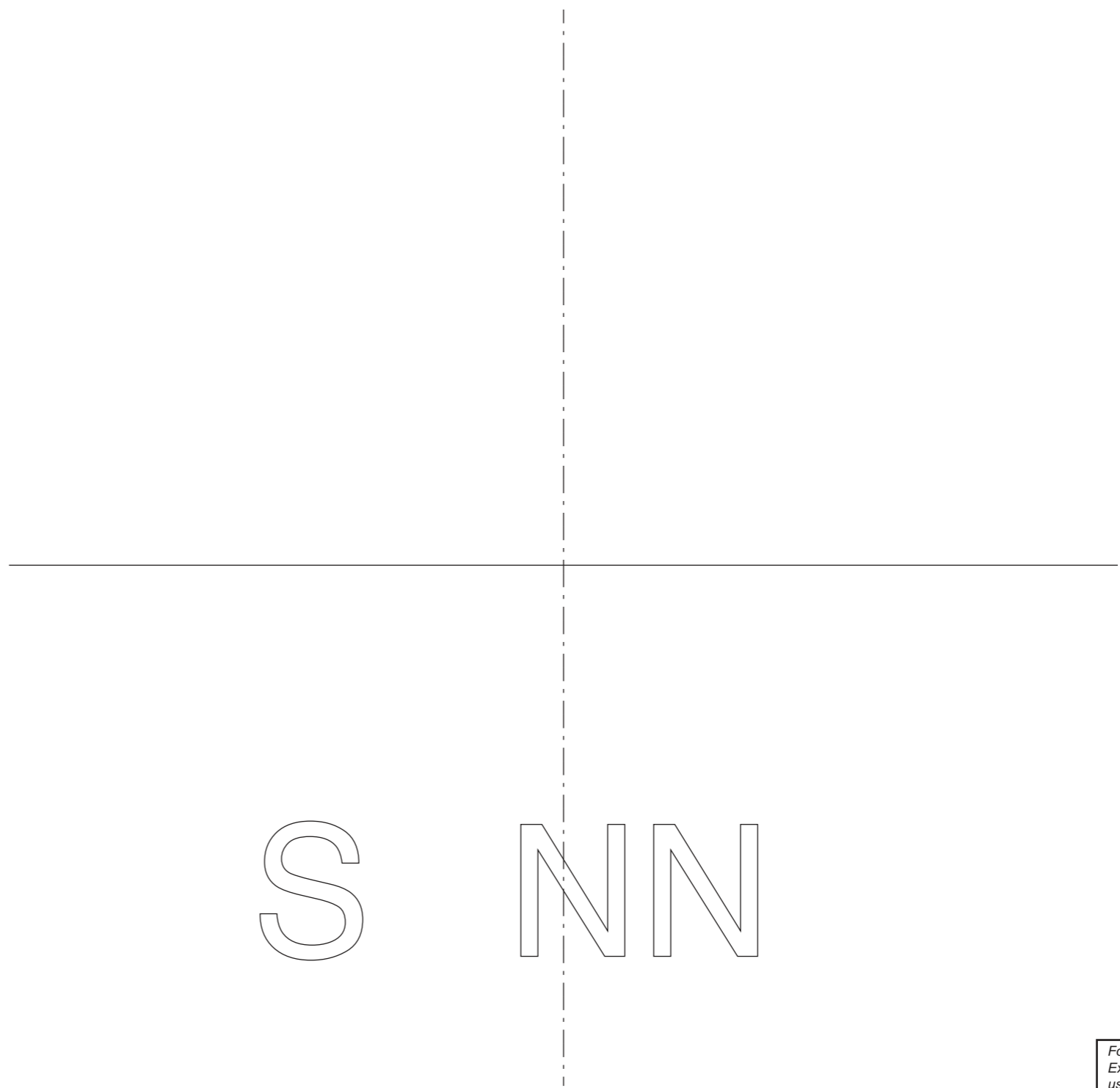

0445/23 May/June 2018 **1 hour**
 © UCLES 2018 DC (LK/AR) 146115/1

Centre Number Candidate Number Candidate Surname Other Names **[Turn over**

For Examiner's use

A3 A toy windmill is made up from the parts shown below.

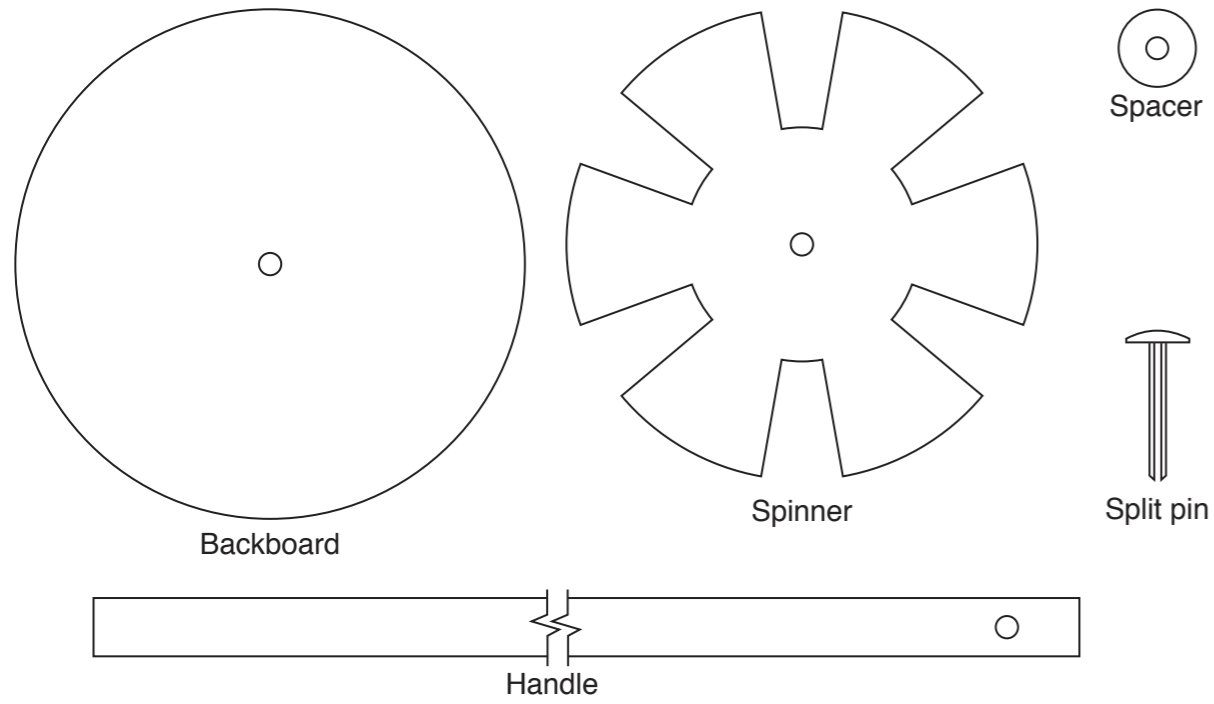

Part	Sizes
Backboard	1mm thick card Ø130
Spinner	1mm thick card Ø120
Spacer	1mm thick card Ø30
Handle	Ø15 dowel, 300mm long

The pieces are assembled as shown below.

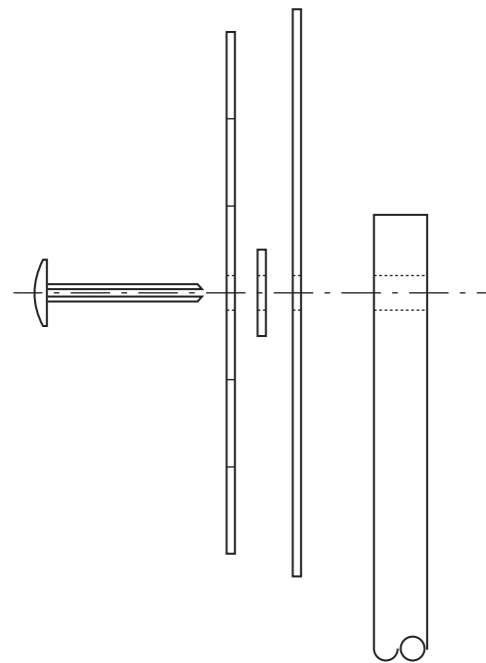

Complete the exploded view of the windmill on the grid by freehand sketching:

- (a) the backboard; [2]
- (b) the spacer; [2]
- (c) the handle. [3]

Do not include the thickness of the card.

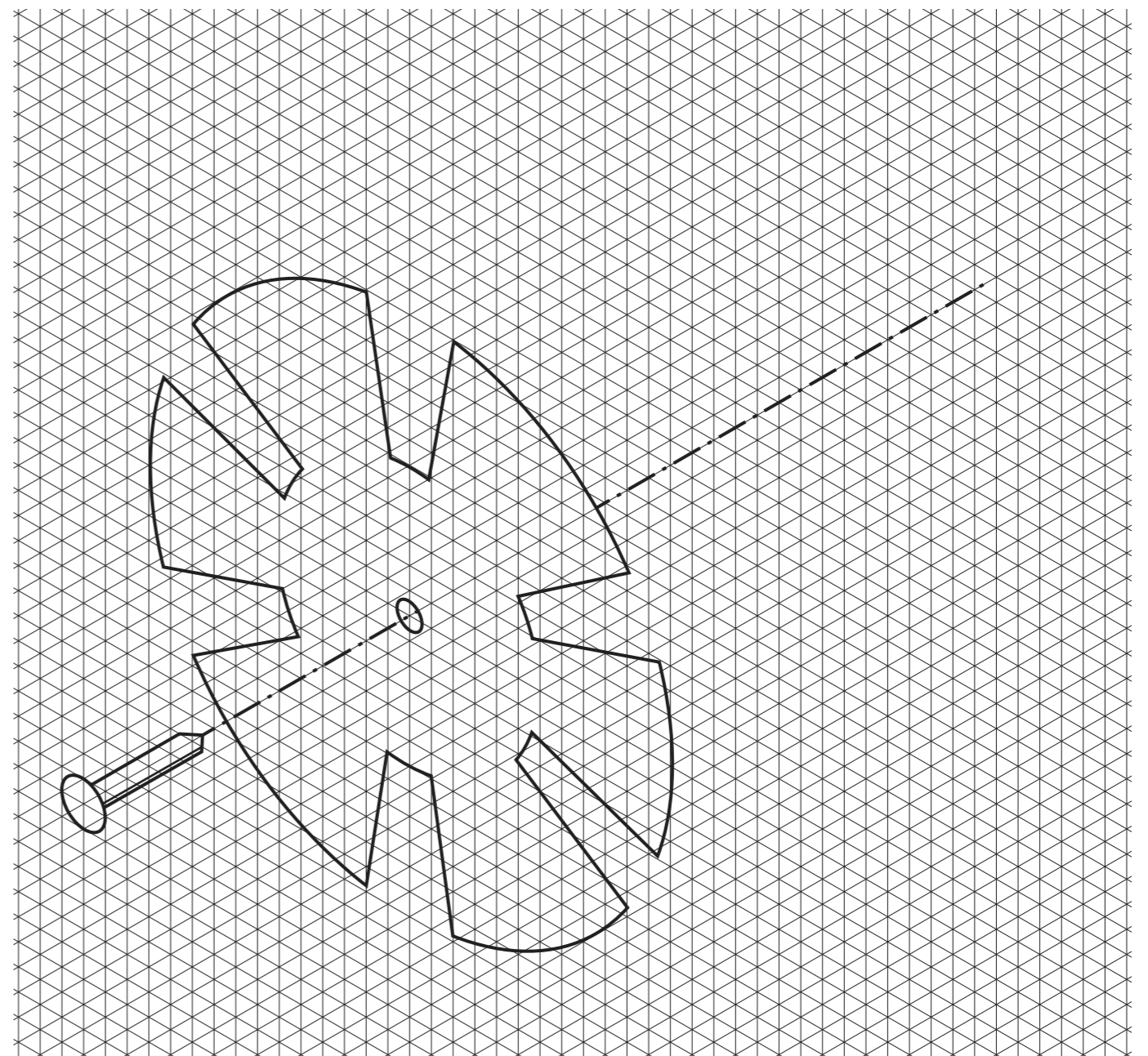

(d) Complete the sectional view of the assembled pieces of the windmill by adding the securing split pin. [2]

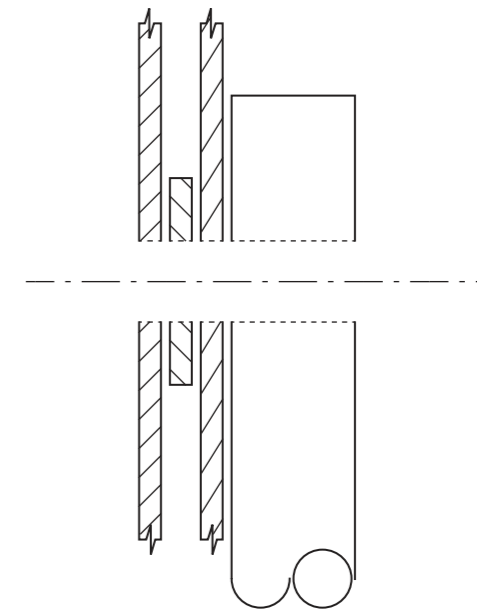

Section B
Answer **either** question **B4** or **B5**.

B4 A toy boat is shown below.

(a) Apply thick and thin line technique to the toy boat. [7]

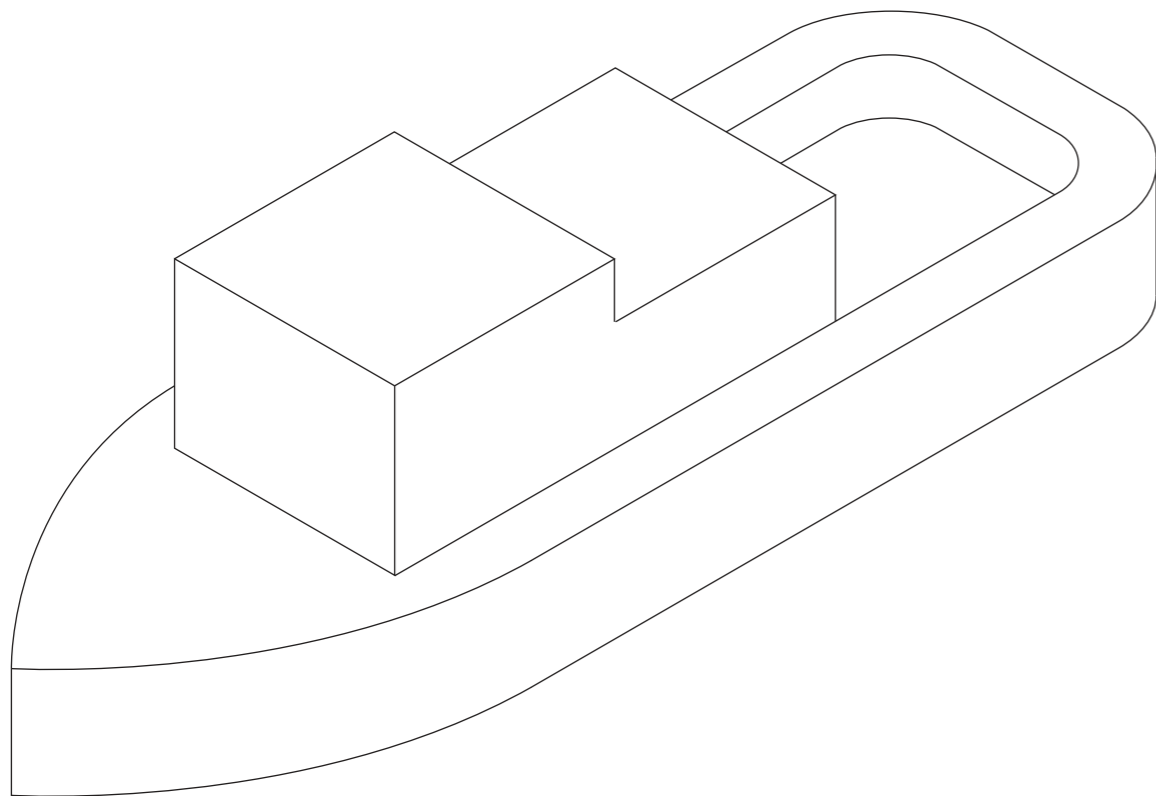

(c) In the space below, complete the orthographic views of the toy boat. [10]

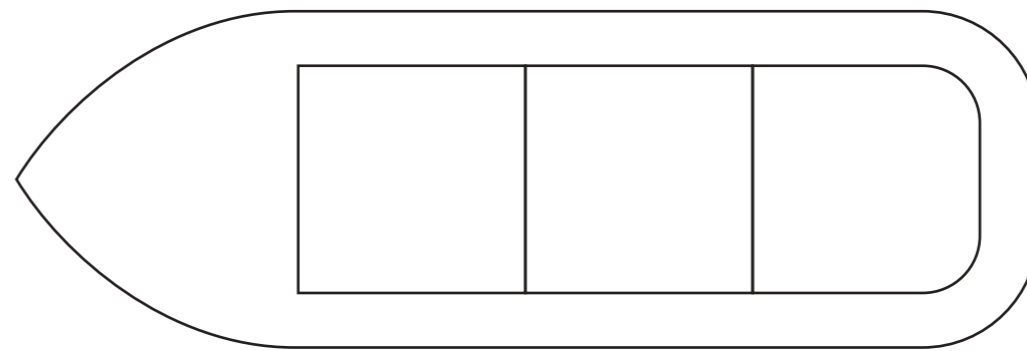

plan

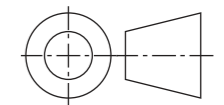

A cylindrical chimney is to be added to the top of the toy boat.

(b) Complete the drawing of the chimney below by constructing the elliptical shape of the top face and by adding the sides of the cylinder. [8]

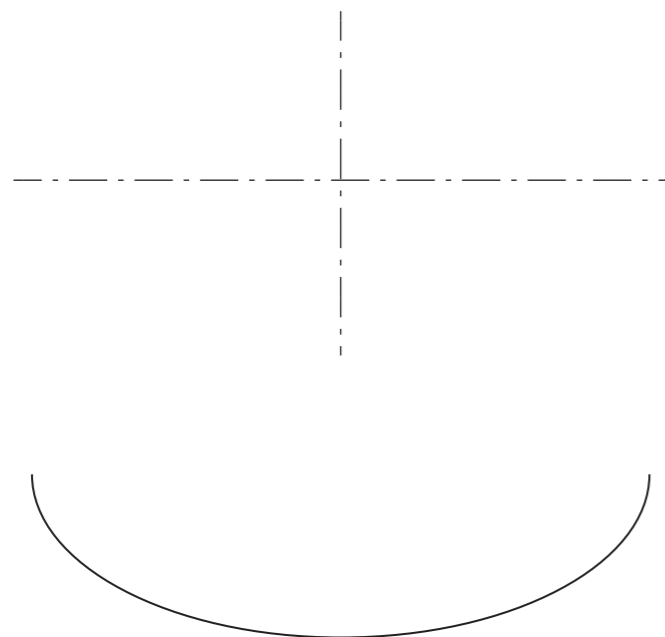

side view

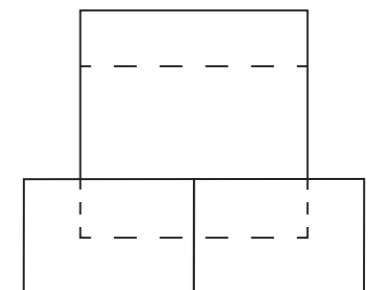

front view

0445/23 May/June 2018 **1 hour**
© UCLES 2018 DC (LK/AR) 146115/1

Centre Number

Candidate Number

Candidate Surname

Other Names

[Turn over

For Examiner's use

B5 Orthographic views of a card model stand for ice cream cones are shown below.

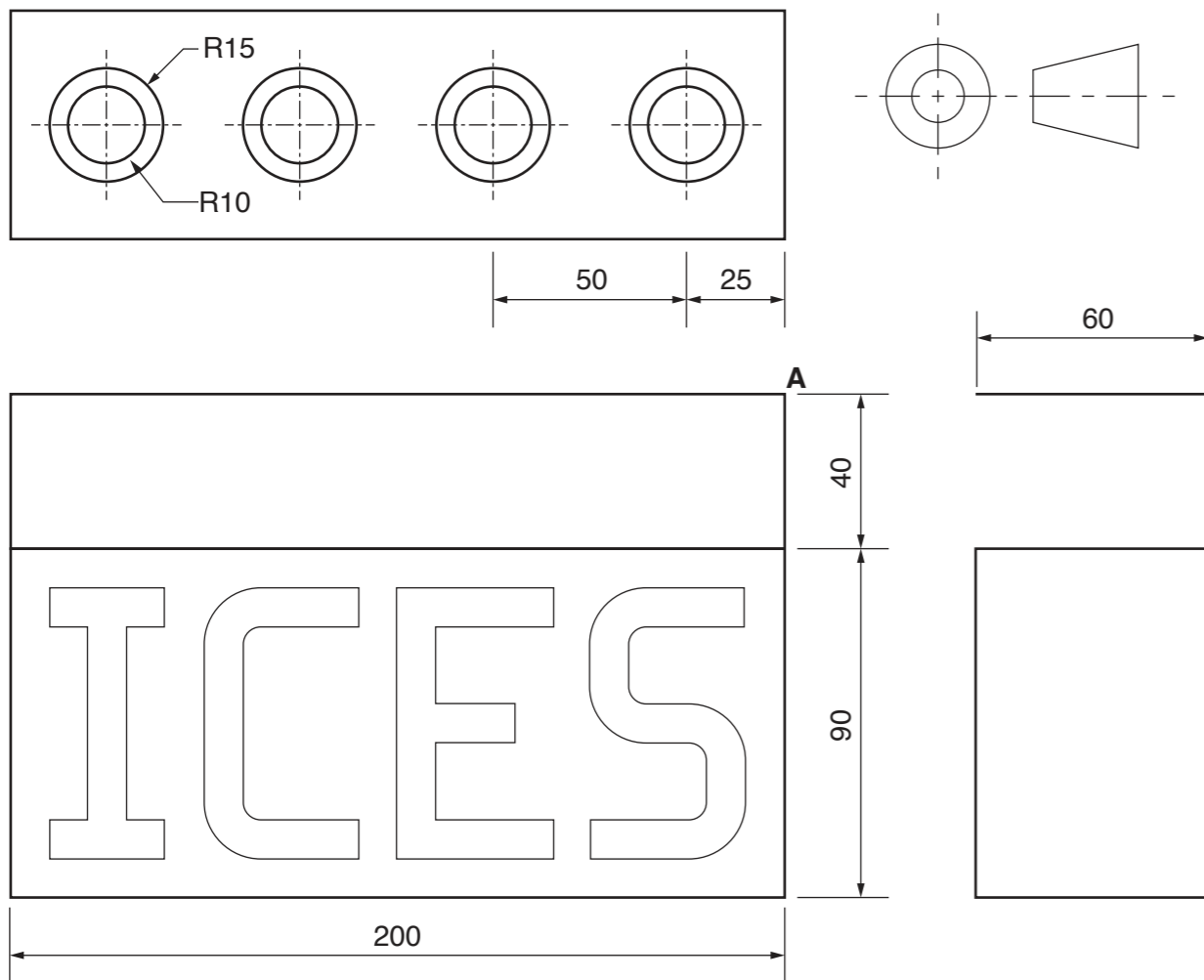

(c) Complete the development (net) of the stand below to a scale of 1 : 2.

[8]

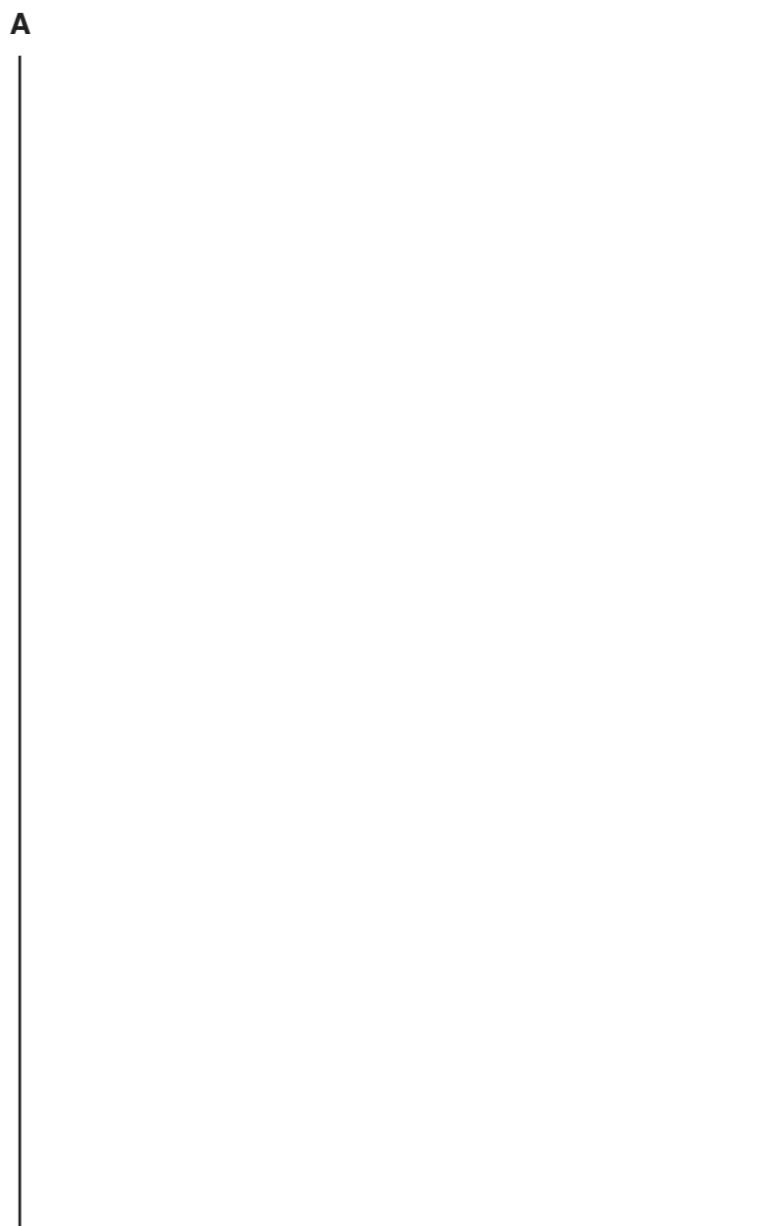

(a) In the space below, draw an estimated two-point perspective view of the model ice cream cone stand to a scale of 1 : 2.

Ignore the thickness of the material and the circular holes.

Corner **A** and the 2 vanishing points have been given.

[12]

(b) Add to the two-point perspective the ICES lettering.

[5]

